



---

# PRODUCT GUIDE

---

## OFFICE & RETAIL



## WAREHOUSE



# BECAUSE WE CARE

We're all about complete office and warehouse solutions and installation services.

It's an investment in time and money, and our qualified team will work with you to maximise your workspace and productivity.

All Storage Systems has been assisting companies with their workspace requirements for over 35 years. We have built up experience and knowledge in the industry that will inspire you and take the pain out of your decision making.

At the heart of our business lies an undeniable commitment to providing the best quality and service for our customers - it's why they keep coming back.

Because we care.



# 7 Reasons to choose All Storage Systems

## **Australian, Family Owned Company**

We're a family owned business that is all about supporting other Aussie businesses.

## **Project Management & Installation**

We have extensive experience in complete project installations and our own team of installers to ensure your job runs smoothly to schedule.

## **Huge Product Range**

Our product range is extensive and many lines are held in stock for immediate despatch.

## **Quality At An Affordable Price**

We have always held to the saying "Give them quality - it's the best type of advertising". You can be assured of quality with All Storage Systems - both in the outcome and the service.

## **Sourcing Service**

The best solution is not always a standard product and our team is continually sourcing items worldwide to ensure you get the best outcome.

## **Advice From The Experts**

We've been helping customers with their storage and equipment for over 35 years. You can trust our advice to be the best!

## **A Team That Cares**

We genuinely care about the outcomes. We are all about the relationship not the transaction.



# ALL STORAGE SYSTEMS

Creating Better Workspaces

We create functional workspaces - both in the office and warehouse areas.

Call us on 1800 772 726 with what you're looking to accomplish.



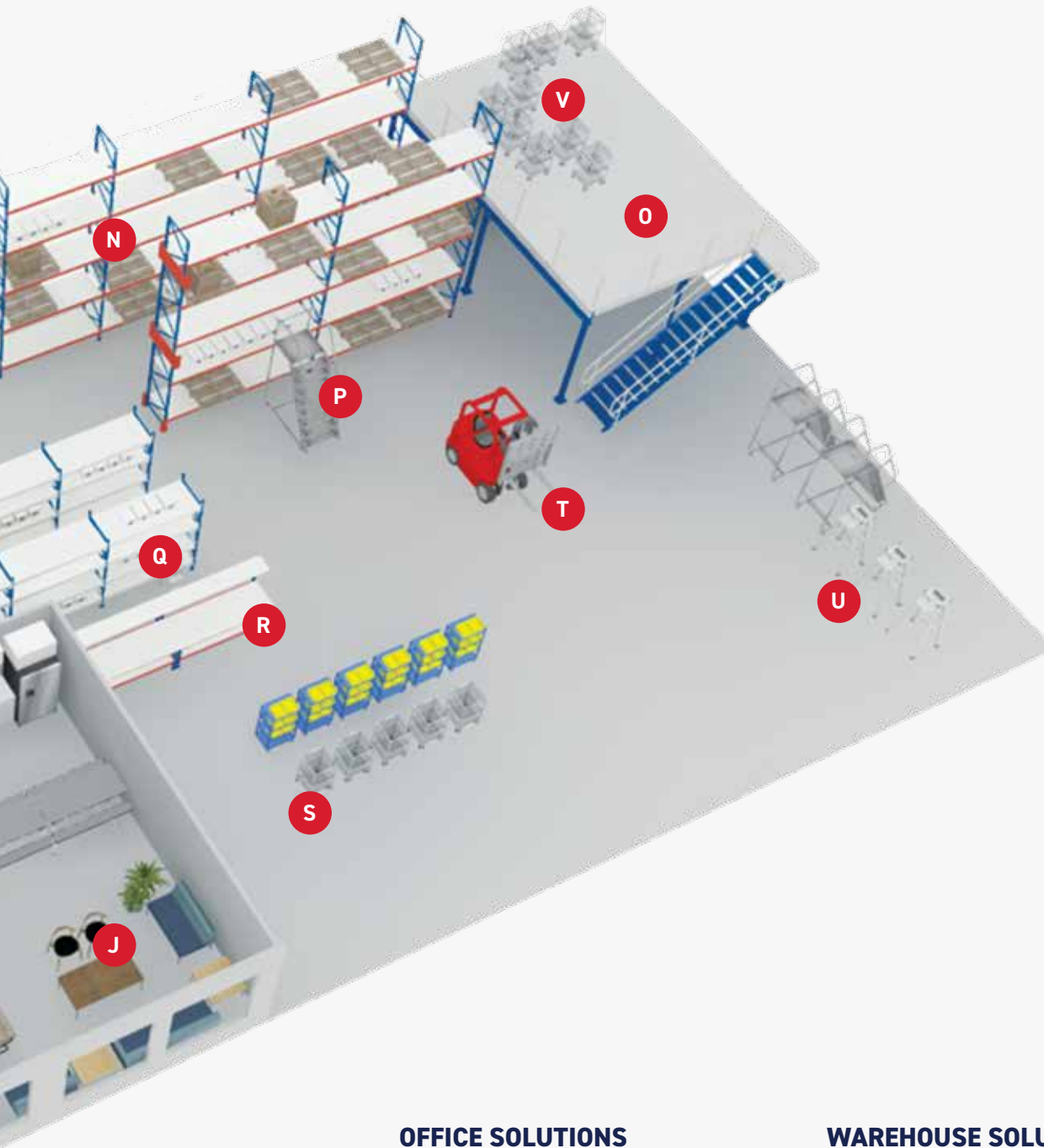

### OFFICE SOLUTIONS

- A. Executive Office Furniture
- B. Reception Desks
- C. Reception Furniture
- D. Workstations
- E. Tambour Door Cupboards
- F. Feature Walls
- G. Whiteboards
- H. Boardroom Furniture
- I. Partitions
- J. Breakout Furniture
- K. Small Parts Storage

### WAREHOUSE SOLUTIONS

- L. Lockers
- M. Safety Cabinets
- N. Pallet Racking
- O. Mezzanines
- P. Ladders
- Q. Longspan Shelving
- R. Workbenches
- S. Trolleys
- T. Pallet Trucks
- U. Materials Handling Equipment
- V. Stillages

# Contact Us



## Visit the All Storage Systems Website

View our Products | Request a Quote or Purchase Online | View our Projects

Visit our  
website

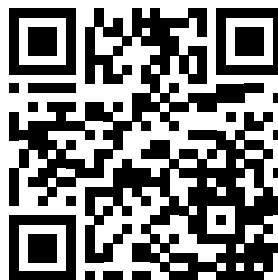

**Visit our Showroom**  
**29 Drummond Rd, Shepparton VIC 3630**

# Warehouse Storage Solutions

- Longspan Shelving
- Cleanspan Shelving
- Tyre Racking
- Pallet Racking
- Mezzanine Floors
- Cantilever Racking
- Small Parts Storage
- Industrial Cabinets
- Dangerous Goods Storage
- Van Racking
- Workbenches
- Plastic Crates

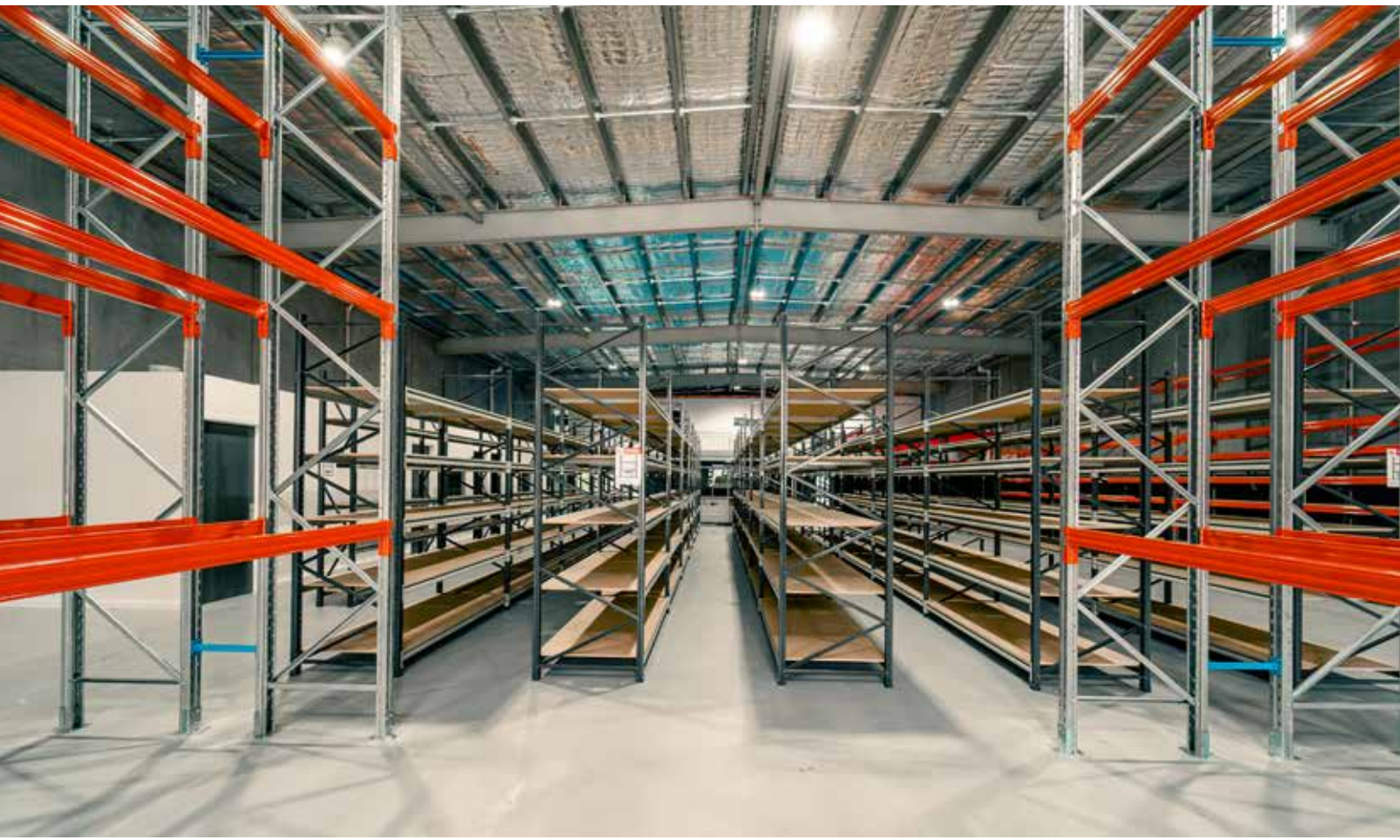

## ALSTOR™ Longspan Shelving



---

### Features:

- A high quality cost effective shelving system available in starter and add-on bays
- Available as a standard unit of 4 shelves

### Frames

- Heights: 2200mm, 3000mm and up to 5100mm (custom)
- Depths: 450mm, 600mm, 900mm

### Beams

- Available in standard Z beams and heavy duty step box beams
- **Z Beam:** Available in 900mm, 1200mm, 1800mm or 2400mm lengths
- **Step Beam:** Available in 900mm, 1200mm, 1800mm or 2400mm lengths

### Shelves

- Available in timber (MDF board), mesh or steel
- **Load capacity:** 400kg per level



# ALSTOR™ Longspan Shelving with Timber Shelves



Shown as Starter and Add-On Bay

A strong, durable and economical solution to your storage needs, longspan shelving with timber shelves is more than adequate for most applications. Suitable for storing everything from small parts to long, heavy and bulky goods.

- Each bay comes with 4 shelf levels, that are 16mm MDF
- Strong durable shelving which will look clean and crisp for years to come
- Superior quality and strength
- Easy to assemble and reconfigure - no special tools required
- Dark grey frame with light grey beams

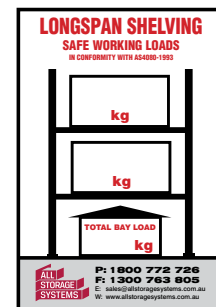

Longspan Safe Working Load Sign - Code: 130023

## Complete Bays

Dimensions H x L x D (mm)	First Bay Code	Add-On Bay Code
2200 x 900 x 450	121685	121720
2200 x 900 x 600	121686	121730
2200 x 900 x 900	121687	121731
2200 x 1200 x 450	121688	121732
2200 x 1200 x 600	121689	121733
2200 x 1200 x 900	121690	121734
2200 x 1800 x 450	121703	121723
2200 x 1800 x 600	121704	121724
2200 x 1800 x 900	121705	121725
2200 x 2400 x 450	121706	121726
2200 x 2400 x 600	121707	121727
2200 x 2400 x 900	121708	121728

## Extra Shelf Levels

Dimensions L x D (mm)	Code
900 x 450	121735
900 x 600	121736
900 x 900	121737
1200 x 450	121738
1200 x 600	121739
1200 x 900	121749
1800 x 450	121743
1800 x 600	121744
1800 x 900	121745
2400 x 450	121746
2400 x 600	121747
2400 x 900	121748

When calculating requirements add 60mm for each end frame.

## APPLICATIONS

- Storerooms
- Warehouses
- Paint & oil storage
- Workshops
- Retail storage

# ALSTOR™ Longspan Shelving with Mesh Shelves



*Shown as Starter and Add-On Bay*

The ideal choice for many applications that require minimal dust and free air circulation. This system is a perfect solution for archive storage.

- Each bay comes with 4 shelf levels
- Excellent value shelving system - strong and durable with many uses
- Ventilation in shelving eliminates dust build up
- Superior quality and strength
- Easy to assemble and reconfigure - no special tools required

## Complete Bays

Dimensions H x L x D (mm)	First Bay Code	Add-On Bay Code
2200 x 900 x 450	121800	121810
2200 x 900 x 600	121801	121811
2200 x 900 x 900	121802	121812
2200 x 1200 x 450	121803	121813
2200 x 1200 x 600	121804	121814
2200 x 1200 x 900	121805	121815
2200 x 1800 x 450	121750	121756
2200 x 1800 x 600	121751	121757
2200 x 1800 x 900	121752	121758
2200 x 2400 x 450	121753	121759
2200 x 2400 x 600	121754	121760
2200 x 2400 x 900	121755	121761

## Extra Shelf Levels

Dimensions L x D (mm)	Code
900 x 450	121840
900 x 600	121841
900 x 900	121842
1200 x 450	121846
1200 x 600	121847
1200 x 900	121848
1800 x 450	121763
1800 x 600	121764
1800 x 900	121765
2400 x 450	121766
2400 x 600	121767
2400 x 900	121768

## APPLICATIONS

Storerooms  
 Warehouses  
 Paint & oil storage  
 Workshops  
 Retail storage

When calculating requirements add 60mm for each end frame.

# ALSTOR™ Longspan Shelving with Steel Shelves



Shown as Starter and Add-On Bay

Longspan shelving with steel shelves is the ultimate choice for a smooth, crisp finish and long term durability.

- Complete bay comes with 4 shelf levels
- Strong durable shelving which will look clean and crisp for years to come
- Superior quality and strength
- Easy to assemble and reconfigure - no special tools required

## Complete Bays

Dimensions H x L x D (mm)	First Bay Code	Add-On Bay Code
2200 x 900 x 450	121778	121785
2200 x 900 x 600	121779	121786
2200 x 900 x 900	121780	121787
2200 x 1200 x 450	121781	121791
2200 x 1200 x 600	121782	121792
2200 x 1200 x 900	121783	121793
2200 x 1800 x 450	121772	121794
2200 x 1800 x 600	121773	121795
2200 x 1800 x 900	121774	121796
2200 x 2400 x 450	121775	121797
2200 x 2400 x 600	121776	121798
2200 x 2400 x 900	121777	121799

## Extra Shelf Levels

Dimensions L x D (mm)	Code
900 x 450	121870
900 x 600	121871
900 x 900	121872
1200 x 450	121876
1200 x 600	121877
1200 x 900	121878
1800 x 450	121879
1800 x 600	121880
1800 x 900	121881
2400 x 450	121882
2400 x 600	121883
2400 x 900	121884

## APPLICATIONS

Storerooms  
Warehouses  
Paint & oil storage  
Workshops  
Retail storage

When calculating requirements add 60mm for each end frame.

## Heavy Duty Workbenches

- For those who want the toughest workbench available!
- 25mm MDF top and 16mm MDF shelf
- Supplied flat-packed for easy assembly
- Optional galvanised benchtops available
- Can also be custom made to your requirements

Code	Description	Dimensions (mm)
111003	1 Shelf	2400L x 900D x 900H
111004	1 Shelf & 1 high back shelf	2400L x 900D x 1500H
111005	1 Shelf & 2 high back shelves	2400L x 900D x 1580H



111003

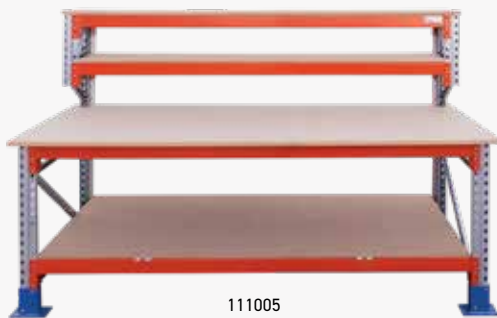

111005



111004

## Industrial Workbench

- Heavy duty steel industrial workbench with optional pegboard panel and drawers
- 1000kg top bench capacity
- Comes standard with adjustable feet for levelling on uneven floors
- Square pegboard and louvre panel are great for organising your tools with bins and hooks
- Drawer capacity - 100kg per drawer
- Talk to our team about the configurations that suit you
- Hooks and bins sold separately

Code	Description
111012	1800mm Workbench
111013	2100mm Workbench
111014	1800mm Backboard
111015	2100mm Backboard
111017	Six drawer tool cabinet



## Medium Duty Workbench with Backboard

- Get organised with our great workbench and backboard package
- Strong construction - 400kg shelf capacity
- 25mm MDF top and 16mm MDF shelf
- Supplied flat-packed for easy assembly
- 2020L x 900D x 1800H

### Includes:

- 1 x Square hole pegboard
- 1 x Louvre Panel
- 8 x Storpak No. 5 tubs
- 8 x Storpak No. 10 tubs
- 12 x Storpak No. 25 tubs
- 1 x Shelf (900mm x 200mm)
- 8 x 100mm straight hooks

Code
828993

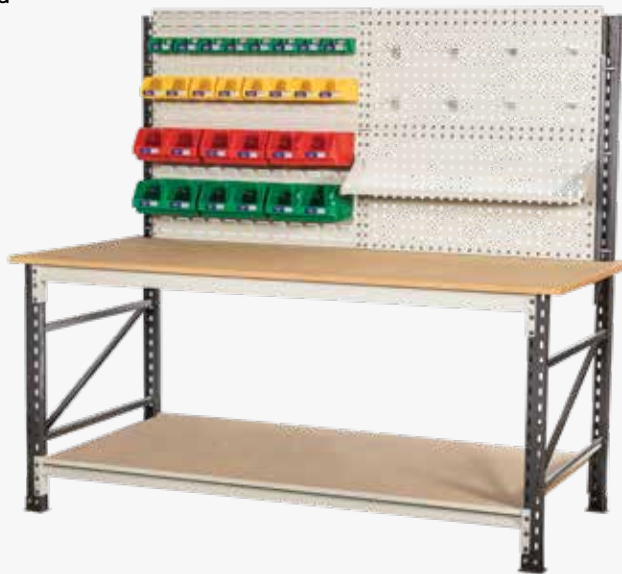

## Medium Duty Workbenches

- Our ever popular workbenches!
- Built to last - don't waste time and money with cheap alternatives
- 25mm MDF top and 16mm MDF shelf
- Available in static or mobile options (mobile includes bottom shelf)
- Other sizes available - phone us to discuss

Code	Description	Dimensions (mm)
111018	Static Workbench - Small	2020L x 650D x 900H
111020	Mobile Workbench - Small	2020L x 650D x 900H
111023	Static Workbench - Medium	2020L x 950D x 900H
111019	Mobile Workbench - Medium	2020L x 950D x 900H
111021	Static Workbench - Medium, with High Back	2020L x 950D x 950H

Code	Description
121744	Extra shelf for small workbench
121745	Extra shelf for medium workbench

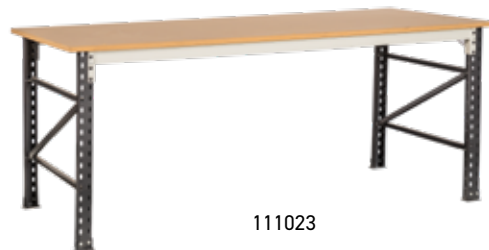

111023

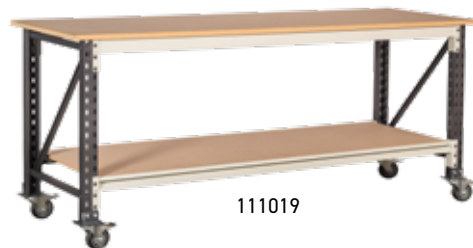

111019



111021



## Custom shelving workbench combinations available

Contact our consultation team to plan your custom solution.



## Pallet Racking

As a leading specialist in pallet racking we have the experience to design, supply and install your racking to your personalised requirements. We understand each clients' needs are individual which is why we work closely with you to design the best system that works to give you optimum storage in the most cost-effective way.



- DOUBLE DEEP RACKING
- PALLET RACKING
- NARROW AISLE RACKING
- DRIVE IN RACKING
- PUSH BACK RACKING
- CARTON FLOW RACKING

### Our Services Include:

- Free no obligation site survey
- Free design service including drawings
- Installation by our trained professional install team

## Galvanised Racking

- Hot-dipped galvanised is specifically designed for protection from all temperatures and environments
- Used for outdoor storage
- Extremely durable

End Frame Dimensions	Beams	Capacity
2400mmH x 838mmW	1372mmL x 80mmH	2000kg
3000mmH x 838mmW	2591mmL x 100mmH	2100kg
3600mmH x 838mmW	2743mmL x 100mmH	2100kg
4200mmH x 838mmW	2591mmL x 120mmH	2900kg
4800mmH x 838mmW	2743mmL x 120mmH	2900kg



## Board Support Bars & Z Clips

- Used in conjunction with timber shelves
- Support bars prevent sagging and supports timber sheeting
- Bars designed to maintain the load capacity of the beam, not increase the safe work load
- Z clips retain the board and stop it from moving from position



Code	Description
130054	Board Supports
130056	Z Clips

## Pallet Racking Mesh Decks

- Ultimate option for storage where airflow and minimal dust are necessary
- Increases lighting - great for dark warehouses
- Suits standard rack size of 838mm
- Mesh size: 50 x 100 x 5.6mm
- Deck capacity 1000kg

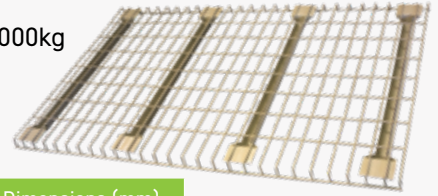

Code	Dimensions (mm)
130050	1250 x 838
130051	1350 x 838

## MDF Board Shelves

- Timber shelves for use on pallet racking
- Quality 16mm board

Code	Dimensions (mm)
130052	2572L x 840D
130053	2720L x 840D



## Magnetic Labeling Roll

- Perfect for steel shelves, pallet racking or cabinets
- Great for changing stock locations
- Write on / wipe off surface
- Easily cut to required length
- Affix to almost anything



Code	Dimensions
130020	50mm x 30m

## Coil / Drum Supports

- Supports the storage of large cylindrical objects
- Ideal for coils or 44 gallon drums



Code	Dimensions (mm)
130057	838

## Hose Hanger

- Designed to bolt around a 50mm beam
- Supports a maximum weight of 70kg evenly distributed



Code	Dimensions (mm)
130058	700 x 48

# ALSTOR™ Rack End Protectors

- Designed to protect your pallet racking from forklift damage
- Solid steel construction

Code	Description	Size
130000	End Protector Single Sided	1125L x 400H x 225W
130001	End Protector Double Sided	2350L x 400H x 225W
130002	Leg Protector	400mm
130003	Corner Protector	400mm

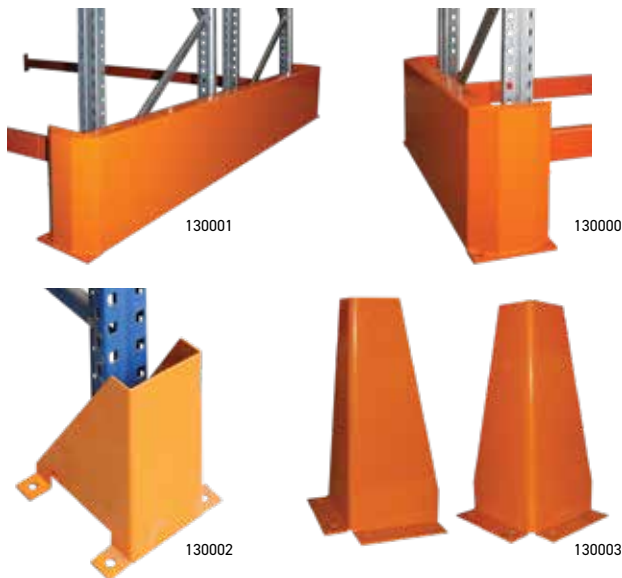

# Pallet Rack Armour

- Installs in seconds - simply clicks to existing racking
- No fixing or bolts required saving damage to floors
- Fully transferable if you have to re-fit or move premises
- Fully tested for front and side impacts
- Impervious to acid, alkali, mould, rust and most solvents
- Cold store safe - effective down to -40°C

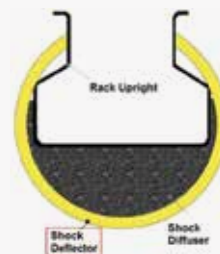

# Safe Working Load Signs

- SWL signs are mandatory when installing new pallet racking or cantilever racking
- Informs the allowable safe limits for loads and safety procedures

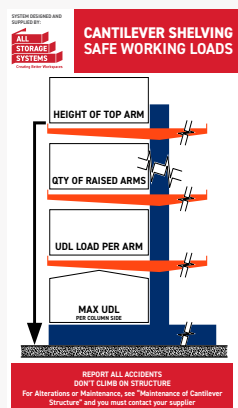
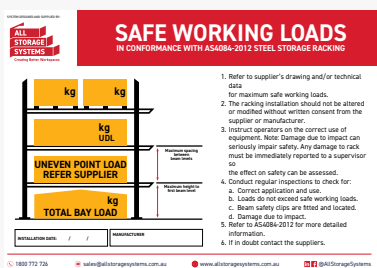

Code	Dimensions (mm)
130021	840 x 450

Code	Dimensions (mm)
130025	300 x 850

# Pallet Racking Audits

Steel storage racking is subject to constant use resulting in damage and general wear and tear. Conducting regular inspections of your pallet racking is essential to ensure a safe work environment and to comply with Australian Standards AS/NZS 4084:2023 and FEM 10.2.04. Pallet racking needs to be audited by competent personnel at least annually. Our experienced team are qualified to look after this for you and ensure your workplace is safe.

## Inspections Include:

- Visual site examination and assessment by qualified personnel
- Compliance report compiled which details risks and recommendations
- Colour coded report supplied showing level of action required







## Mezzanine Floors

All Storage has been designing, manufacturing and installing mezzanine floors for over 10 years. The perfect option to increase space in your current warehouse – some of the uses for mezzanine floors include:

### Storage

Increase your storage space in a warehouse with integrated racking or extra space for bulk storage and archiving.

### Office

Additional workspace for staff offices, meeting areas, break out rooms or control rooms.

### Retail

Increase the space on your shop floor, adding stockroom space, storage for large or specialist items or extra office space.

### Hospitality

Add extra seating or serving areas, storage or stock rooms for food preparation.



# Cantilever Racking

ALSTOR™ Cantilever Racking provides maximum storage capability for storing long, awkward and oversized goods and is easily accessible. It is available in various single sided and double sided configurations and heights.

ALSTOR™ Cantilever Racking is available in light duty, which has a safe working load (SWL) of 250kg per arm, medium duty, which has a SWL of 1000kg per arm, and heavy duty, which can be engineered to suit your SWL requirements.

ALSTOR™ Cantilever Racking is available in two finishes - powder coated and hot-dipped galvanised.

## Light Duty

Standard Heights	2000, 2400, 3000, 3600, 4200mm
Standard Bay Widths	900, 1200, 1500mm
Standard Arm Lengths	700, 900, 1200mm
Standard Arm Capacity	250kg per arm

## Medium Duty

Standard Heights	2438, 3048, 3658, 4250, 4877, 6096mm
Standard Bay Widths	900, 1200, 1500, 1800mm
Standard Arm Lengths	900, 1200, 1500mm
Standard Arm Capacity	1000kg per arm



Medium Duty Cantilever

### STORAGE APPLICATIONS

- Plywood/Chipboard
- Timber
- Furniture
- Pipe
- Structural members
- Sheet metal
- Tubing
- Doors
- Pallets
- Conduit
- Extrusions
- Rolls
- Building materials



Light Duty Cantilever



Medium Duty Cantilever

## Vertical Cantilever Racking

Standard Depth	840mm (single sided)
Standard Widths	1372, 2590mm
Standard Heights	2400, 3000, 3600, 4200, 4800mm

### APPLICATIONS

Aluminum extrusions

Timber

Conduit

...much more



## Cable Racking

ALSTOR™ Cable Racking is a system designed to provide direct access to rolls of cable by using fixed and interchangeable levels, thus optimising every available space. The system can be used for a variety of cable roll weights and sizes, allowing easy access and visibility to the product.





## ALSTOR™ Tyre Racking

Our tyre storage solution has been developed specifically for the challenges faced when handling and storing tyres. Highly configurable the system can be used as small stand alone racks for 12 tyres, to modular mezzanine storage for larger quantities.

- Accommodates all tyre sizes
- Uses a bolt-free lock-in system - no tools required
- OH & S compliant
- Highly configurable so you can change your storage as required
- Tyres are accessible from both sides of the rack

Standard Depths	450, 600mm
Standard Widths	900, 1200, 1800, 2400mm
Standard Heights	2200, 3000, 5100mm



## Mobile Storage Tyre Racks

- Available in both mechanical and manual operation
- Great space saver - only one aisle space required
- Ask our team about the best option for your needs

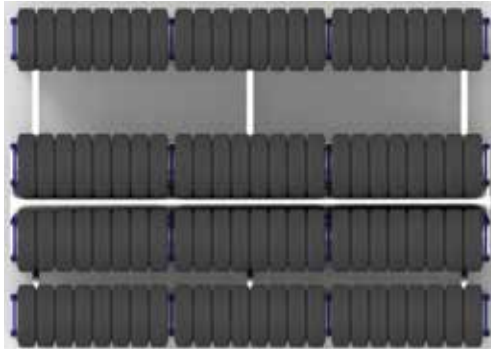

## Modular Raised Tyre Storage System

- Modular tyre storage is the most popular design worldwide
- Can be added to in all 4 directions as your business expands
- Excellent value for money
- Easy to install and reconfigure



## ALSTOR™ Tyre Chute

- Quickly and safely transfer tyres from mezzanine to floor level
- Accommodates tyres of all sizes
- Made in Australia
- **Built to customer requirements**

## Securespan Shelving

- Versatile system that turns standard longspan into secure storage
- Available in stand alone bays or can join onto adjoining longspan runs
- Ideal for the security of both hazardous or valuable materials



Code	Dimensions (mm)
120820	2200H x 1800L x 450D
120821	2200H x 1800L x 600D
120822	2200H x 1800L x 900D

## Johnson-Built Kwiklock Shelving

- Economical shelving system for lightweight storage
- Easy to lock together assembly - no tools required
- Available with MDF shelves
- Great for office storage, garages and workshops
- 350kg UDL per shelf level
- 4 shelf levels (extra shelves are available)



Code	Dimensions (H x L x D)
123360	2150mm x 450mm x 450mm
123361	2150mm x 600mm x 600mm
123362	2150mm x 900mm x 450mm
123363	2150mm x 900mm x 600mm
123364	2150mm x 1200mm x 450mm
123365	2150mm x 1200mm x 600mm
123366	2150mm x 1500mm x 450mm
123367	2150mm x 1500mm x 600mm
123368	2150mm x 1800mm x 450mm
123369	2150mm x 1800mm x 600mm



Top Cap



Kwiklock Connector



Base Plate

## Johnson-Built Kwiklock Coolroom Shelving

- Economical shelving system for lightweight storage
- Easy to lock together assembly - no tools required
- Available with mesh shelves
- 350kg UDL per shelf level
- 4 shelf levels (extra shelves are available)



Code	Dimensions (H x L x D)
123375	2150mm x 1800mm x 600mm

## Post Real Tuff Shelving

- Our most popular commercial shelving for coolrooms and freezers
- 100% Australian made
- Anti-microbial protection built in to the shelving
- Shelves lift off for ease of cleaning - dishwasher safe
- Will stand temperatures between -30°C and 90°C
- Fully adjustable shelves and feet

DEPTHS (mm)	WIDTHS (mm)	HEIGHTS (mm)
300, 450, 525, 600	600, 750, 900, 1050, 1200, 1350, 1500, 1650, 1800	1200, 1800, 2000



## Post Wire Grid Shelving

- Solid roll formed frame gives clean look and allows room for pricing and product name display
- Wire shelves with standard zinc electroplate and lacquer finish
- Designed to prevent dust build up and allow air circulation
- Fully adjustable shelves and feet
- Choose from either zinc with lacquer or polished stainless steel finish



DEPTHS (mm)	WIDTHS (mm)	HEIGHTS (mm)
300, 450, 525, 600	600, 750, 900, 1050, 1200, 1350, 1500, 1650, 1800	1200, 1800, 2000



## Angle Post Shelving

- Economical shelving option for coolrooms and storerooms
- Choose either ABS, plastic shelves or wire shelves (ABS have limited depth options)
- Available in zinc coated, powder coated or stainless steel
- Shelf dividers, baskets and back ledges also available



DEPTHS (mm)	WIDTHS (mm)	HEIGHTS (mm)
300, 375, 450, 525, 600	600, 750, 900, 1050, 1200, 1350, 1500, 1650, 1800, 1950, 2100, 2250, 2400	1350, 1800, 2000, 2300





## ALSTOR™ Cleanspan Chrome Wire Shelving

A multi-purpose high quality chrome wire adjustable shelving system suited to the medical and hospitality markets. Providing extra air-flow and conforming to Australian Health Standards, this versatile shelving is a system the market won't go past.



- Clips together for fast assembly
- Highly flexible with adjustable shelving
- High quality ticket stripping attaches for a clean, organised labelling system
- Wide range of sizes to suit your application
- All bays come with 4 shelves

Static	Mobile	Extra Shelf	Dimensions (mm)
128100	128140	128000	914L x 457D x 1800H
128101	128141	128001	914L x 610D x 1800H
128102	128142	128002	1219L x 457D x 1800H
128103	128143	128003	1219L x 610D x 1800H
128104	128144	128004	1524L x 457D x 1800H
128105	128145	128005	1524L x 610D x 1800H
128106	128146	128006	1829L x 457D x 1800H
128107	128147	128007	1829L x 610D x 1800H

Static Height = 1800mm. Mobile Height = 1930mm.

## ALSTOR™ Cleanspan Accessories

- Cleanspan ledges and dividers retain and divide products
- Ticket stripping is available in 2 lengths or can be cut to size
- Bridging clips create corner units for maximum storage



Rear Ledges



Side Ledges



Dividers



Bridging Clips

Ticket Stripping

Code	Size (mm)
128014	914 x 100
128015	1219 x 100
128016	1524 x 100
128017	1829 x 100

Code	Size (mm)
128012	457 x 100
128013	610 x 100

Code	Size (mm)
128010	457
128011	610

Code
128018

Code	Size (mm)
128025	150
128026	2000



## ALSTOR™ Cleanspan Overhead Rail Units

- ALSTOR™ Cleanspan Overhead Rail Units are the ideal option for high density storage in sterile environments
- Configurable to your personalised requirements
- Recommended site analysis, design and quotation for this type of storage



## ALSTOR™ Cleanspan Trolleys

- ALSTOR™ Cleanspan trolleys are the perfect means for transporting items in high sterile areas
- Buffers on all castors to prevent damage to walls and equipment
- 2 lockable castors per trolley
- Accessories, including ledges, dividers and ticket stripping, are also suitable for Cleanspan trolleys

2 Tier	3 Tier	Dimensions (mm)
128200	128208	914L x 457W x 1065H
128201	128209	914L x 610W x 1065H
128202	128210	1219L x 457W x 1065H
128203	128211	1219L x 610W x 1065H
128204	128212	1524L x 457W x 1065H
128205	128213	1524L x 610W x 1065H
128206	128214	1829L x 457W x 1065H
128207	128215	1829L x 610W x 1065H





## Activity and Combination Racks

Ideal solution for organising a storeroom, despatch area or showroom.

- Available in both mobile and static bays
- Removable and interchangeable tubs



### Monster Combination Rack

- 10 x Stack & nest crates
- 2 Timber shelves
- 2200H x 2400L x 600D

Code	Description
120041	Mobile
120040	Static



### Maxi Combination Rack

- 8 x Stack & nest crates
- 2 Timber shelves
- 2200H x 1800L x 600D

Code	Description
120042	Mobile
120038	Static

## Activity Racks

Ideal solution for organising a storeroom, despatch area or showroom.

- Available in both mobile and static bays
- Removable and interchangeable tubs

### APPLICATIONS

- School sports storage
- Picking and despatch areas
- Servicing areas

### Ultra Activity Rack

- 20 x No. 4 crates
- 2200H x 1800L x 450D

Code	Description
120030	Mobile
120031	Static



### Maxi Activity Rack

- 12 x Stack & nest crates
- 2200H x 1800L x 600D

Code	Description
120034	Mobile
120035	Static



### Super Activity Rack

- 16 x No. 240 bins
- 2200H x 1800L x 450D

Code	Description
120032	Mobile
120033	Static



### Johnson-Built Mega Rack

- 16 x No. 10 bins
- 2150H x 1800L x 600D

Code	Description
120050	Static



### Johnson-Built Mini Rack

- 12 x No. 240 bins
- 2150H x 900L x 450D

Code	Description
120051	Static



## ALSTOR™ Rolled Edge Shelving

Rolled Edge Shelving can be used wherever light to medium duty storage is required, from warehouses to offices, hospitals to libraries, museums to retail outlets and general storerooms.

- Shelving is available as single bays or adjoining bays
- Shelves are adjustable to suit your requirements
- Shelving is made of steel with a powder coated finish
- Shelf capacity is up to 100kg per shelf
- Accessories include dividers, small parts containers etc
- Colour - light grey

First Bay	Add-On Bay	Extra Shelf	Dimensions
122300	122310	122320	900L x 300D
122301	122311	122321	900L x 400D
122302	122312	122322	900L x 600D
122303	122313	122323	1200L x 300D
122304	122314	122324	1200L x 400D
122305	122315	122325	1200L x 600D



## ALSTOR™ Rolled Edge Shelving with Parts Trays

### 900mmW x 2175mmH x 300/400mmD

300mmD Bay of shelving incl:

- 13 x 900mmW x 300mmD Adjustable shelves
- 56 x 141000 Parts trays with dividers
- 28 x 141002 Parts trays with dividers

Code

122330

400mmD Bay of shelving incl:

- 13 x 900mmW x 400mmD Adjustable shelves
- 56 x 141001 Parts trays with dividers
- 28 x 141003 Parts trays with dividers

Code

122331



## ALSTOR™ Rolled Edge Shelving with Storpak Bins

### 900mmW x 2175mmH x 300mmD

Bay of shelving incl:

- 8 x 900mmW x 300mmD Adjustable shelves
- 16 x N60 Storpak bins
- 10 x N120 Storpak bins

Storpak bin colours available:

Blue, Green, Red & Yellow

Code

122332



## Hanger Rack System

- Perfect way to organise a workshop or production area
- Available with either square hole hanger board, louvre panels or a combination of both
- Large range of accessories available to suit your needs (sold separately)
- Choose either mobile or static unit
- Mobile comes with 2 lockable castors

Code	Description	Dimensions (mm)
120230	Mobile with Bins	1600H x 600W x 980L
120231	Static with Bins	1450H x 600W x 980L
120200	Mobile without Bins	1600H x 600W x 980L
120202	Static without Bins	1450H x 600W x 980L



## Square Hole Hanger Board

- Square hole hanger boards can be mounted onto benches, walls, racking or shelving
- Keyholes at the rear of each panel for mounting - presenting a clean durable appearance
- Available with both louvre panel or square hole

Code	Description	Size
120210	Hanger Board w Square Holes	900 x 450mm
120211	Hanger Board w Louvred Panel	900 x 450mm
120212	Screwdriver Holder: holds 7	390mm long
120213	Saw Holder Pair	90mm long
120214	Galv Belt Hook	
120215	Galv Round Hook	23 x 55mm
120216	Galv U-Hook	70 x 35mm
120220	Galv U-Hook	23 x 35mm
120221	Straight Hook	25mm long
120217	Straight Hook	50mm long
120218	Straight Hook	100mm long
120219	Shelf	900 x 200mm
120222	Spanner Holder	135mm long
120225	3 Prong Hook	150mm long
120223	Double Hook	25mm long
120224	Double Hook	75mm long

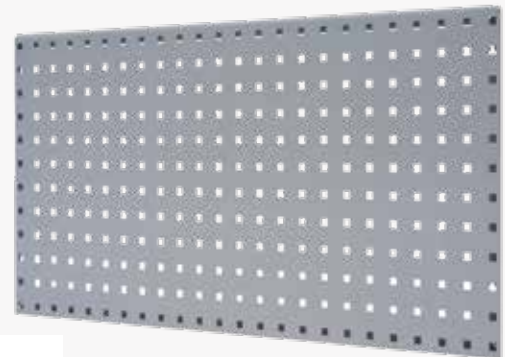



## Mighty Parts Trolley

- Strong powder coated steel frame
- Louvre panels with removable Storpak bins

### Includes:

- 2 x Storpak No. 120 bins
- 4 x Storpak No. 60 bins
- 12 x Storpak No. 25 bins
- 8 x Storpak No. 10 bins
- 16 x Storpak No. 5 bins

Code	Description	Size
120232	Mobile - With Bins	1200H x 450W x 660L
120204	Mobile - Without Bins	1200H x 450W x 660L

## ALSTOR™ Wire Baskets

- ALSTOR™ Wire Baskets are the ideal solution for medical and hospitality areas
- Easy to clean metal construction dissipates static electricity eliminating dust
- Can be attached to louvre panel or used on our cleanspan shelving system
- Dividers and label holders attach for organising
- Quick to adjust
- Wire grid small enough to prevent items falling through

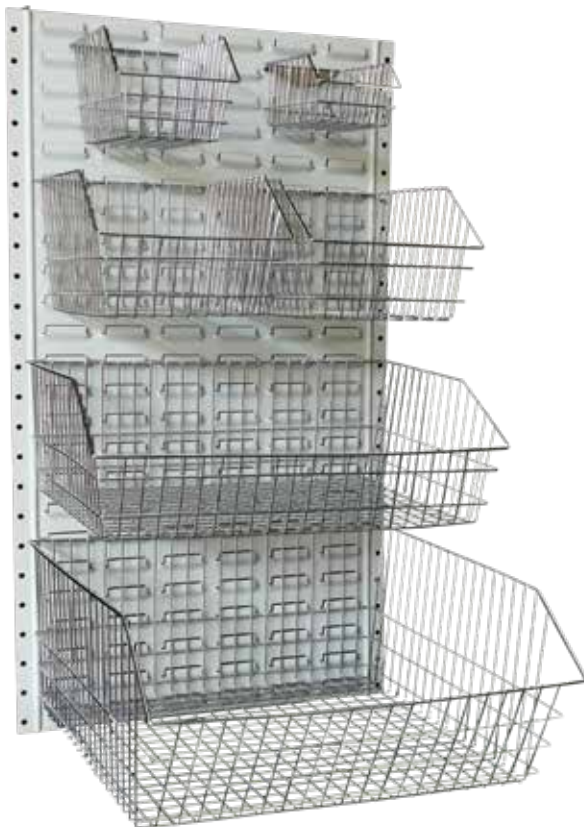

### Wire Baskets

Code	Capacity	Dimensions (mm)	Qty per pack
142700	1 Litre	175L x 100W x 85H	6
142701	2.5 Litre	220L x 135W x 125H	6
142702	6 Litre	275L x 200W x 165H	6
142703	12 Litre	300L x 435W x 165H	6
142704	24 Litre	450L x 435W x 220H	6

### Dividers (not pictured)

Code	Description	Qty per pack
142705	Suits 6L wire basket	6
142706	Suits 12L wire basket	6
142707	Suits 24L wire basket	6

### Label Holders (not pictured)

Code	Dimensions (mm)	Qty per pack
142708	105 x 25	100
142709	105 x 40	100
142710	105 x 60	100

## Louvre Panel

- Strong powder coated steel panels that attach to walls or shelves
- Designed to be used with Storpak bins, Visi-Paks, Supra bins or Cleanspan wire baskets
- Before installation ensure that the wall the panel will be affixed to can support the necessary weight

Code	Dimensions (mm)
142600	900W x 450H
142601	450W x 450H
142602	450W x 900H
142603	450W x 1200H
142604	450W x 1800H



## Louvre Panel Kits



### 900mm Louvred Panel Kit with Storpak Bins

**Includes:**

- 1 x 142602 Louvred panel
- 6 x 140025 Storpak bins
- 16 x 140010 Storpak bins
- 8 x 140005 Storpak bins

Code

140100

### 1800mm Louvred Panel Kit with Storpak Bins

**Includes:**

- 1 x 142604 Louvred panel
- 1 x 140120 Storpak bin
- 4 x 140060 Storpak bins
- 9 x 140025 Storpak bins
- 20 x 140010 Storpak bins
- 12 x 140005 Storpak bins

Code

140101

### 900mm Louvred Panel Kit with Visi-Paks

**Includes:**

- 1 x 142602 Louvred panel
- 2 x 142002 Large Visi-Paks
- 3 x 142001 Medium Visi-Paks
- 8 x 142000 Small Visi-Paks

Code

140102

## Storpak Bins

- Storpak bins are the most popular option for storage bins
- Stackable or use on louvre and square hole panels
- Six colour options available in 6 sizes
- Made in Australia

Code	Description	Dimensions (mm)	Ctn Qty
140005	N5	100W x 115D x 60H	12
140010	N10	100W x 170D x 85H	6
140025	N25	133W x 220D x 125H	6
140060	N60	200W x 270D x 165H	6
140080	N80	200W x 440D x 165H	6
140120	N120	410W x 275D x 165H	5
140240	N240	410W x 440D x 210H	1

### Accessories

Code	Description
140000	140060/140120 Divider
140001	140240 Divider
140002	Labels - 24 Pack



## RK Shelf Containers

- Durable containers for high density storage of small parts
- Adjustable compartments with optional dividers
- Designed to hang off the edge of the shelf for single handed picking
- Large label holder for easy parts identification

Code	Dimensions (mm)
141200	408L x 162W x 115H
141201	508L x 162W x 115H
141202	Dividers to Suit



Available in blue only

## Parts Trays

- Strong, durable and lightweight containers for effectively keeping your small parts organised
- Integral hand grips panel for easy use
- Internal dividers supplied as pictured, extra dividers also available
- Grey in stock ready for despatch
- Also available in blue, green, red or yellow

Code	Dimensions (mm)	Ctn Qty
141000	300L x 100W x 100H	24
141001	400L x 100W x 100H	24
141002	300L x 200W x 100H	12
141003	400L x 200W x 100H	12
141004	600L x 100W x 100H	12
141005	600L x 200W x 100H	6
141006	300L x 300W x 100H	8
141007	400L x 300W x 100H	8
141008	600L x 300W x 100mmH	
141020	Divider - Suits 100W Trays	50
141021	Divider - Suits 200W Trays	50
141022	Divider - Suits 300W Trays	20





## Series 400 Bins

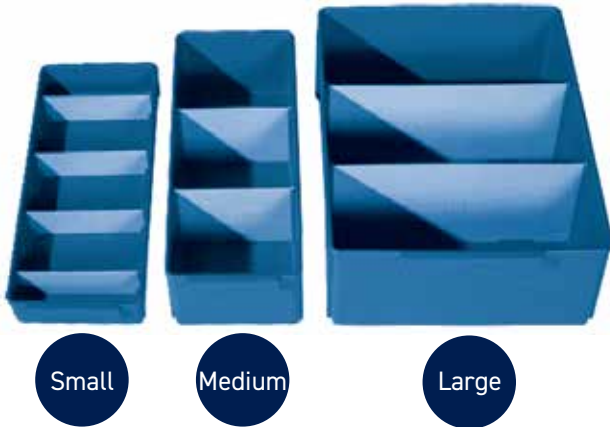

- Strong sturdy trays for small parts
- Available in 3 sizes with optional adjustable dividers
- Available in black or blue

Code	Description	Dimensions (mm)	Ctn Qty
141100	Small	400L x 146W x 50H	18
141101	Medium	400L x 146W x 100H	8
141102	Large	400L x 296W x 140H	3

## Series 600 Bins



- Same range as the Series 400 only longer
- Available in 3 sizes with optional adjustable dividers
- Available in grey or blue

Code	Description	Dimensions (mm)	Ctn Qty	Extra Divider Code
141130	Small	600L x 148W x 50H	30	141150
141131	Medium	600L x 148W x 100H	15	141151
141132	Large	600L x 298W x 140H	4	141152

## Supra Bins



- Sturdy small parts trays with lower front lip for clear access to contents
- Includes a safety stop at the back for use in shelves
- Available in red, blue, green, grey or orange
- Trays can be divided both in length or width
- Stackable

Code	Description	Dimensions (mm)
141304	Supra Bin SB4	285L x 180W x 145H
141306	Supra Bin SB6	435L x 180W x 145H

## Visi-Pak

- Small parts storage system with a removable transparent tilt drawer
- Contents are clearly displayed and are kept dust free
- Supplied with clips which enables them to mount onto louvre panels or screw into walls
- Unique interlocking design which allows them to connect side by side or on top
- Made in Australia
- Hospital grade - bacterial and chemical free



Code	Dimensions (mm)	Ctn Qty
142000	103W x 83D x 120H	12
142001	154W x 126D x 180H	6
142002	208W x 167D x 235H	6

## Stack & Nest Black Crates

- Very popular crates due to their ability to either stack or nest
- Made from tough, durable UV-resistant polypropylene
- Manufactured from recycled plastic - not suitable for food storage
- Ideal for engineering, warehouse or distribution areas

Code	Description	Dimensions (mm)	Capacity
163005RB	No. 7	645L x 413W x 210H	32L
163006RB	No. 10	645L x 413W x 276H	52L
163007RB	No. 15	645L x 413W x 397H	68L

Code	Description
163008RB	Lid



## Stack & Nest Coloured Crates

- Food grade polypropylene
- Suitable for small goods manufacture, meat trades or general warehousing
- Crates will either stack or nest depending on which way they are stored
- Manufactured from tough, durable UV-resistant plastic

Code	Description	Dimensions (mm)	Capacity
163005	No. 7	645L x 413W x 210H	32L
163006	No. 10	645L x 413W x 276H	52L
163007	No. 15	645L x 413W x 397H	68L



## Enviroskate

- Heavy duty enviroskate designed to work with the Stack & Nest crates
- Massive load rating of 600kgs
- Two back wheels have brakes to secure on sloped ground and stop skate spinning around
- Rounded corners to minimize any accidental bump damage



Code	Description
161102	Enviroskate

## Hobby Box

- Available in blue, green, red or black
- Perfect for cleaning, catering, food handling, refrigeration, storage areas or warehouses
- Quality Australian made product
- Stackable - making them great for storage
- UV stabilised polypropylene



Code	Dimensions (mm) (Ext.)	Capacity
163034	356 x 356 x 292	27L

## Side Access Crates

- Designed for the need of the automotive industry
- Very heavy duty crates for tough industrial environments
- Stackable - even when crates are filled
- Quality Australian made
- Manufactured from food grade polypropylene



Code	Dimensions (mm)	Capacity
163035	580 x 385 x 320	50L

## Security Crates

- Lockable and tamper proof
- Internal hanging rails fits 60 files comfortably
- Nests when empty or stacks when closed
- Very versatile crate making it ideal for any warehouse, transportation or simply secure safe storage



Code	Dimensions (mm)	Capacity
163030	478 x 337 x 320	34L
163031	671 x 450 x 315	68L

## Nest Crates

- Industrial strength nesting crates
- Flat bottom makes them perfect on conveyors or roller systems
- Stocked in blue, black, yellow, red or natural, other colours available



Code	Description	Dimensions (mm)
163000	13.5L	430 x 323 x 127H
163001	22L	430 x 323 x 210H
163002	Lid to suit crates	

## Nally Buckets

- Tough plastic buckets to suit any industrial applications
- Made in Australia
- Manufactured from food grade polypropylene
- Tight fit sealing lid



Code	Dimensions (mm) (Ext.)	Capacity
161200	300 x 295 x 286H	13.6L
161201	360 x 295 x 280H	18.2L
161202	360 x 360 x 342H	22.7L
161203	Lid to suit 13.6L	
161204	Lid to suit 18.2L & 22.7L	

## Round Brute®

- Multi purpose storage and handling containers
- Strong, snap-on lids
- Built in handles for lifting and anti-jam nesting
- Rugged dolly available to make containers mobile



Code	Capacity	Dimensions (mm)	Code	Description
165000	37L	396ø x 435H	165010	Lid to fit 165000
165001	75L	495ø x 582H	165011	Lid to fit 165001
165002	121L	558ø x 695H	165012	Lid to fit 165002
165003	166L	610ø x 800H	165013	Lid to fit 165003
165004	208L	673ø x 838H	165014	Lid to fit 165004
			161100	Brute Dolly to suit 75L-208L containers
			161101	Universal Drum Dolly

## Stacking Totes

- Tote boxes provide a highly versatile, inter-stackable storage system with limitless applications
- Solid injection moulded construction ensures stability when stacking
- Box shape maximises storage space in crate
- Suitable for conveyor or roller systems
- Available in white and blue



Code	Description	Dimensions (mm)
163020	13L	442L x 330W x 130H
163021	22L	442L x 330W x 219H
163022	32L	442L x 330W x 305H
163023	Lid to suit	

## Document Storage

- Keep important papers, safety data sheets or manuals secure, clean and dry
- Can be mounted onto safety cabinets, equipment or machinery
- High density polyethylene - durable, rustproof and easy to clean
- Weather resistant with gasket seal closure
- Also great option for portable document storage

Code	Description	Dimensions (mm)
A	Document Storage Box A4; Top Opening	317H x 260W x 57D
B	Document Storage Box A5; Front Opening	285H x 210W x 49D
C	Document Storage Box A4; Front Opening	370H x 279W x 54D
D	Document Storage Tube	371H x 94W x 94D
E	Document Storage Box A4 Binder	500H x 490W x 130D

E



A



B

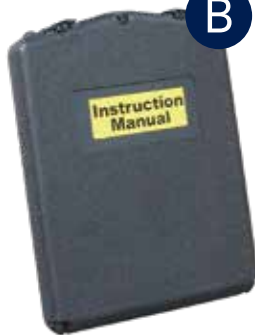

C

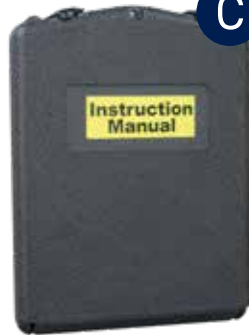

D



## Safety Signs

- Each sign is 600mm x 450mm
- Metal construction
- 5 different styles available

Code	Description
242300	Four Face Multi Sign
242301	Twin Face Multi Sign
242302	Caution Forklifts in Use Sign
242303	No Entry Authorised Persons Only Sign
242304	High Visibility Clothing Must Be Worn Sign



## ALSTOR™ Industrial Storage Cabinet



- Heavy duty industrial storage cabinet made from reinforced sheet metal
- 3 point locking system
- Available in both full height or half height
- Comes standard with adjustable shelves
- Drawer units are an optional extra

Code	Dimensions (mm)
110010	900 x 900 x 450D
110011	1800 x 900 x 450D



## ALSTOR™ Drawer Units



- Drawer units available in both 100mm or 200mm
- Drawers come standard with 15 compartments (4 partitions and 10 dividers)

Code	Dimensions (mm)
110012	100
110013	200

## ALSTOR™ Industrial Drawer Unit



Code
110014

- Extra strong drawer unit for storing tools in workshops
- Lockable with a 3 point locking system
- Drawers come standard with adjustable dividers
- Drawer capacity - 75kg
- Dimensions: 900mmH x 900mmW x 450mmD

## ALSTOR™ Mobile Tooling Cabinet



Code
110015

- Heavy duty tooling cabinet for industrial workshops
- Drawers run on high quality mechanical bearings for smooth long lasting operation
- All drawers come with adjustable steel dividers
- Single key lock design for each drawer
- Drawer capacity - 100kg
- Dimensions: 565mmW x 580mmD x 900mmH

## Parts Storage Cabinets

- Strong fully welded steel construction cupboards
- Lockable with a 3 point locking system
- Fully adjustable shelves
- Well priced option for parts storage



### Mini Cabinet

Includes Parts Trays:

24 x 141000

8 x 141002

Code	Dimensions (mm)
110002	900H x 920W x 360D



### Minor Cabinet

Includes Storpak Bins:

8 x 140060

4 x 140120

Code	Dimensions (mm)
110003	900H x 920W x 360D



### Mega Cabinet

Includes Parts Trays:

40 x 141000

24 x 141002

Code	Dimensions (mm)
110004	1800H x 920W x 360D



### Major Cabinet

Includes Storpak Bins:

16 x 140060

8 x 140120

Code	Dimensions (mm)
110005	1800H x 920W x 360D

# Economy Van Rack

- Cost efficient storage option for spare parts and tools in trade vehicles
- Fully adjustable galvanised steel shelves
- 100% Australian made
- Strong, removable and interchangeable Storpak bins
- 1250mmL x 1000mmH x 300mmD

**Includes:**

- 8 x Storpak No. 10 bins
- 12 x Storpak No. 25 bins
- 4 x Storpak No. 60 bins
- 2 x Storpak No. 120 bins

Code
170000



# Rolashelf System

- The ultimate option for vehicle storage!
- Engineered, designed and made in Australia since 1982
- Endless options of configurations to suit your customised needs



Code	Dimensions (mm)
172000	1755W

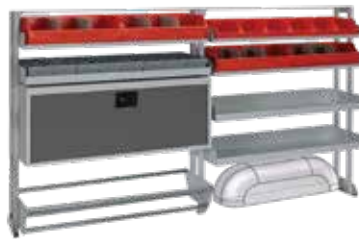

Code	Dimensions (mm)
172001	1755W



Code	Dimensions (mm)
172002	890W



Code	Dimensions (mm)
172003	890W



Code	Dimensions (mm)
172004	1060W





# Rolacase Systems

A unique high density small parts storage system that enables you to take your storage system with you wherever you go. Engineered, designed, tested and manufactured in Australia since 1985.



Code  
144000

370mm x 370mm x 85mm. 20 adjustable compartments and 1 tool compartment. Colour: Orange case with solid lid.



Code  
144001

370mm x 370mm x 85mm. 20 adjustable compartments and 1 tool compartment. Colour: Orange case with clear lid.



Code  
144002

370mm x 370mm x 85mm. Limited edition charcoal case with charcoal lid. 20 adjustable compartments, 1 tool compartment in front of case.



Code  
144003

370mm x 370mm x 85mm. Limited edition charcoal case with clear lid. 20 adjustable compartments, 1 tool compartment in front of case.



Code  
144004

370mm x 370mm x 85mm. 1 large compartment (will take RCFIS/2) and 1 tool compartment in front of case.



Code	Desc.
144006	Solid Lid
144007	Clear Lid

370mm x 370mm x 130mm. 1 large tool compartment and lift-out compartment tray. Colour: Orange case with solid/ clear lid.



Code  
144008

370mm x 370mm x 130mm. 1 large compartment and lift-out compartment tray. Includes 144010 Quick Kit.



Code  
144010

310mm x 210mm x 50mm. 10 small compartments and 1 tool compartment.



Code  
144009

First Aid Kits suitable for vehicles and other workplaces in Victoria.



Code  
144020

Cases included.

Drawer system to take 2 x 144006/144007 Rolacases. 420mmW x 460mmD x 350mmH



Code  
144021

4 Series metal drawer cabinet includes 2 x RC401, 2 x RC403.



Code  
144022

Cases included.

Drawer cabinet to take 3 x 144000 Rolacases. 420mmW x 460mmD x 325mmH



Code  
144023

Cases included.

Drawer cabinet to take 2 x 144006/144007, 1 x 144004 & 4 x 144000 Rolacases. 838mmW x 460mmD x 325mmH



Code  
144024

Cases included.

Drawer cabinet to take 10 x 144000 Rolacases. 840mmW x 460mmD x 547mmH



Code  
144025

Cases included.

Cabinet Trolley to take 7 x 144000 & 2 x 144006/144007 Rolacases. 839mmW x 460mmD x 960mmH

## Storage Cupboard with Mesh Doors

- Allows easy viewing of products
- 5 adjustable shelves
- 50kg UDL per shelf level
- Lockable mesh doors
- Powder coated doors and cabinet
- Easy to assemble



Code	Dimensions (mm)
310090	1850H x 900W x 450D

## Flammable Liquid Storage

- Ideal for the safe everyday storage of most classes of dangerous goods
- Keep your staff safe and reduce fire risks
- Designed and manufactured in Australia

Code	Dimensions (mm)	Capacity	Shelves	Doors
152207	860W x 860D x 1825H	350L	3	2
152205	1100W x 500D x 1825H	250L	3	2
152203	1100W x 460D x 1295H	160L	2	2
152202	935W x 620D x 770H	100L	1	2
152201	515W x 460D x 1065H	60L	2	1
152200	515W x 460D x 770H	30L	1	1

Flammable Liquid Cabinets are also available for the following:



## Aerosol Cases

- Safely store aerosols in heavy duty steel cages
- Built to last - durable powder coated green finish
- Comes complete with all necessary signage

Code	External Dimensions (mm)	Max Capacity
152000	400H x 500W x 250D	12 Can
152001	500H x 700W x 300D	60 Can
152002	900H x 850W x 400D	108 Can
152003	900H x 1655W x 400D	216 Can
152004	1800H x 850W x 400D	216 Can
152005	1800H x 1655W x 400D	432 Can



## Forklift LPG Stores

- Designed specifically to store forklift LPG cylinders
- Cylinder chain restraint included
- Designed and manufactured in Australia

Code	Description	Dimensions (mm)
151000	2 Cylinder Storage	1023H x 750W x 450D
151001	4 Cylinder Storage	1050H x 750W x 750D
151002	6 Cylinder Storage	1050H x 1100W x 750D
151003	12 Cylinder Storage	2000H x 1100W x 750D



## Gas Cylinder Storage

- Heavy duty steel construction cages designed to store gas cylinders
- Each cylinder is individually restrained
- Crane lifting lugs
- Fold down ramp and fork slot channels for easy moving
- Lockable door

Code	Description	Dimensions (mm)
151030	Single Side Access	1900H x 950W x 550D
151031	Single Side Access	1900H x 950W x 950D
151032	Single Side Access	2000H x 1340W x 960D
151033	Single Side Access	2000H x 1740W x 1170D
151034	Dual Side Access Open Cage	2000H x 860W x 970D
151035	Dual Side Access Open Cage	2000H x 1230W x 970D
151036	Dual Side Access Secure Cage	2000H x 860W x 970D
151037	Dual Side Access Secure Cage	2000H x 1230W x 970D



Gas Cylinder Storage Units are also available for the following:



## Corrosive Substance Storage Cabinets

- Non-metallic safety cabinets for storing corrosive substances
- Self closing doors with pivot pins - no hinges to corrode
- Comes complete with all essential signage
- Profiled top for decanting where required
- 100% Australian made

Code	Description	Dimensions (mm)
155020	2 Shelves; 50L Capacity	800H x 500W x 470D
155021	4 Shelves; 100L Capacity	800H x 985W x 470D
155022	4 Shelves; 160L Capacity	1225H x 985W x 470D
155023	6 Shelves; 250L Capacity	1820H x 1100W x 450D



## PPE Storage Cabinets

- Providing PPE is a legal requirement in most workplaces and keeping your PPE clean and safe is important
- High quality powder coated steel finish in hi-vis grey and orange
- Fully lockable with safety signage fitted to the exterior
- Wall brackets designed to stop taller cabinets from tipping
- 100% Australian made

Code	Description	Dimensions (mm)
150000	Double door; 4 shelves + 1 hanging rail	1795H x 915W x 475D
150001	Single door; 3 shelves	1195H x 560W x 325D
150002	Double door; 3 shelves	1195H x 1160W x 325D
150003	Single door; 2 shelves	1490H x 560W x 325D
150004	Single door; 2 shelves	700H x 500W x 300D
150005	Wall brackets	
150006	Manifest Cabinet for storing emergency information or site plans	500H x 490W x 130D



## Bunded Pallets

- Economical and safe storage solution that complies to AS3780
- Provides a spill capacity of 230L
- 100% Australian made
- Pallet truck and forklift friendly
- UV stable heavy duty construction



Code	Description	Capacity
240000	Polyethylene 2 Drum Bund	230L
240001	Polyethylene 4 Drum Bund	230L

## Low Profile Bunded Pallets

- For products that need to be accessed regularly, low profile is ideal
- Bunds join together easily with connectors
- Built in handles and spill gutters
- Made of tough UV stable poly construction
- 100% Australian made



Code	Description	Platform Height (mm)	Capacity
240010	2 Drum Bund	1290W x 710D x 150H	100L
240011	4 Drum Bund	1275W x 1275D x 160H	190L
240013	Polyethylene Ramp	810W x 1290D x 180H	
240014	Connector Kit		

## Bunded Shelving

- Bunded shelving provides a compact, safe storage for 20L drums
- Holds up to 9 x 20L drums
- Shelves are perforated to avoid spilt liquid on shelf
- Comes flat-packed - installed in minutes



Code	Description	Dimensions (mm)
240060	Single Depth	1275 x 740 x 1900H
240061	Double Depth	1275 x 1275 x 1900H

## Tri-Bund Flexible Bunding

- Flexible and cost effective solution for bunding in light traffic areas
- Caters to all types of traffic
- Bunding returns to original shape immediately after being driven over
- Prevents spills from progressing in or out of protected areas
- Simple and quick to install



Code	Description
240030	2m Tri-Bund Flexible Bund
240031	90° Joiner
240032	Polyurethane Floor Adhesive 370gsm
240033	PVC Adhesive 500mmL

## ALSTOR™ Mesh Galvanised Collapsible Cage

- Stackable cages for transport or storage – ideal for any production, warehouse or storage application
- Easily collapses without any required tools
- Fitted with drop down access gates on two sides
- Can be transported with forklift or pallet jack

Code	Dimensions (mm)	Capacity
254003	1125W x 1125D x 1000H	1000kg
254004	Lid to suit collapsible cage	
254005	Divider to suit collapsible cage	



## Collapsible Mesh Stillage Cage

- Strong versatile storage cage for transport or warehousing
- Simply collapses in seconds without the need of a tool
- Drop down gate with self-locking latches provides access even when stacked
- Ability to stack up to 4 high
- Strong zinc plated steel construction
- Lockable lid, mesh dividers and castor kits also available

Code	Dimensions (mm)	Capacity
254001	1200W x 1000D x 900H	1000kg



## Stackable Stillages

- Excellent form of storage for the warehouse or yard
- Designed for easy transportation of long awkward objects
- Stackable to 4 high
- Side poles are removable for collapsing

Code	Dimensions (mm)	Capacity
254000	1200H x 1430W x 1060D	1000kg

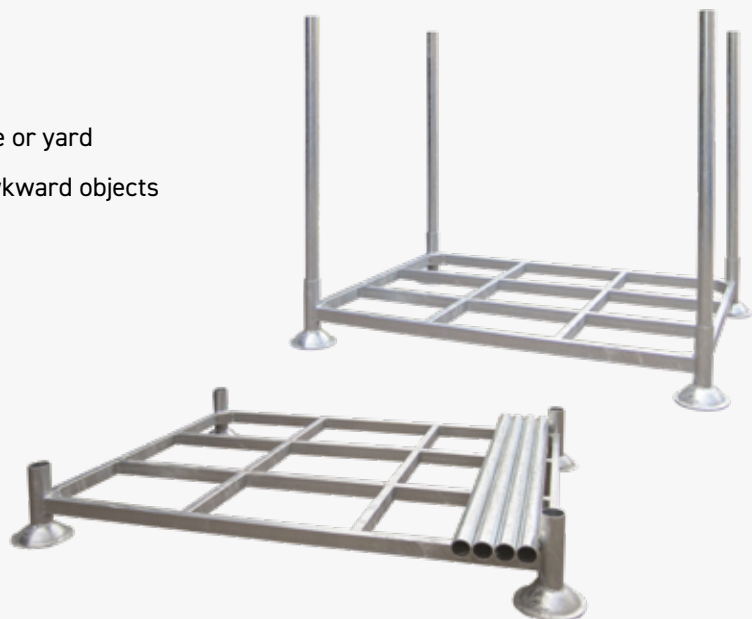

## ALSTOR™ Bolt On Cage

- Bolt on design ensures extra strength and no movement
- Stackable and rackable
- Pallet rack safe
- 2 way forklift access
- 2 way pallet truck access
- Swinging gate on all sizes
- Half fold down gate on one side (825mm high only)
- Includes timber pallet

Code	Dimensions (mm)
244501	500H
244502	825H

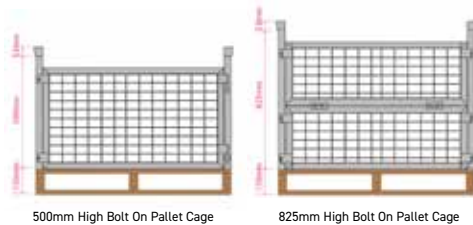

## ALSTOR™ Steel Cage

- Includes pine pallet
- Drop down gate provides access even when stacked
- Zinc plated finish
- One person operation: easy to operate or fold
- Ergonomic: easy access to the products
- Good product visibility
- No detachable parts or loose parts

Code	Dimensions (mm)
244503	500H
244504	900H

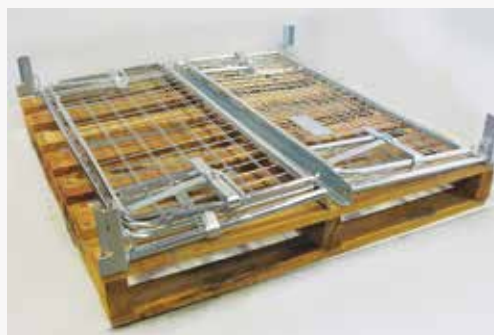

## All-Terrain Scissor Lift

- Scissor lift trolley suitable for any uneven areas
- Easy foot operation lifts the table
- Positive breaking system on rear wheels
- Table size: 1000 x 500mm
- Table height: 340/1000mm



Code  
251010

200 kg capacity

## Hand Pallet Truck

- Standard pallet truck for all warehouses
- Totally sealed hydraulic pump with slow lowering hand control valve
- 3 position control handle
- Fully adjustable push rod under forks



Code Fork Height  
250000 75 - 185mm

2500 kg capacity

## High Lift Pallet Truck

- Designed to elevate skids to an ergonomically safe working height
- Stabilisers ensure maximum stability



Code Fork Height  
250002 85 - 800mm

1000 kg capacity

## Manual Hydraulic Scissor Lifts

- Hydraulic scissor lift tables take the strain out of loading and unloading items
- Table elevates by a foot operated pump and lowers by hand release trigger
- Durable powder coated finish
- Many options available - call and discuss your needs with our team

Code	Lifting Capacity	Max. Platform Height (mm)	Min. Platform Height (mm)	Platform Size (mm)
251000	150kg	750	220	450W x 700L
251001	300kg	880	285	500W x 815L
251002	500kg	880	285	500W x 815L
251003	350kg	1300	355	500W x 910L
251004	750kg	900	420	510W x 1000L
251005	700kg	1500	450	610W x 1200L
251006	500kg	915	286	810W x 1600L
251007	1000kg	1400	286	750W x 2050L





## Forklift Safety Cage - Fully Welded

- Only safe and approved way to lift personnel to a height with a forklift
- Designed to carry 2 people (250kg max)
- Skid resistant floor plates
- Inward opening self closing door
- Australian made to high quality standards



Code	Dimensions (mm)
252001	1200 x 1200 x 1000



## Forklift Safety Cage - Collapsible

- Folds away in minutes - great for storage
- Inward opening, self closing door
- Complies with Australian Standards (AS-2359-1)



Code	Dimensions (mm)
252002	1200 x 1200 x 1000



## Forklift Safety Cage - Zinc Plated

- Manufactured to meet Australian Standards (AS 2359-1)
- Zinc plated finish
- Designed to carry 2 people (250kg max)
- Mesh safety screen
- Toe boards on all sides with skid resistant floor plate
- Inward opening, self closing door
- Internal handrail with safety loops to hook safety harness
- Full length fork sleeves
- Castors can be fitted to the base of the cage for easy manoeuvrability in warehouse or yard
- Floor dimensions inside: 1000mm x 1100mm
- Fork pocket size: 160mm x 60mm
- Supplied flat-packed



Code  
252000

250 kg  
capacity

## Forklift Safety Harness

- Energy absorbing 2m lanyard
- Lightweight and comfortable
- Rear attachment point
- Fully adjustable leg, shoulder and chest straps

Code  
252008

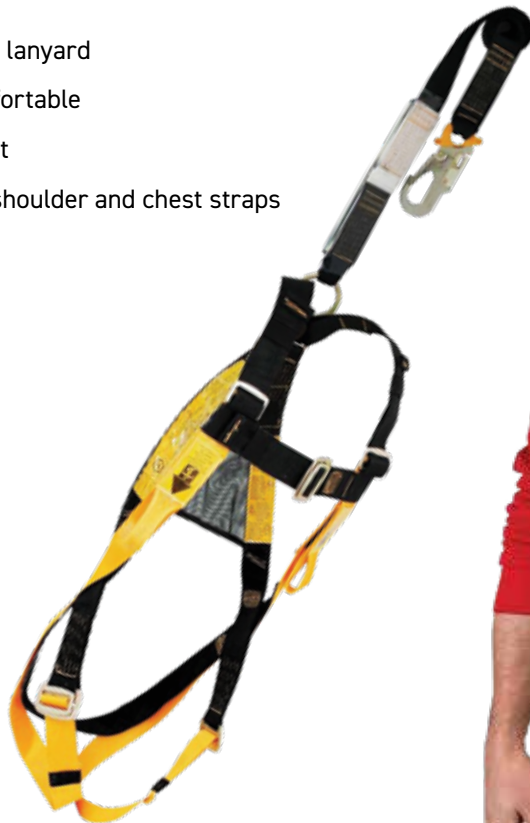

## Container Ramp

The container ramp has a self-levelling lip designed for bridging into a standard container even if the ground is not level. The ramp foot has handles which allows it to be easily folded back for access to slots.

- Capacity: 6500kg
- Unit weight: 275kg
- Finish: Painted yellow
- Width: 2200mm
- Length: 2000mm
- Fork pocket size: 165mm x 60mm
- Fork pocket centres: 775mm

Supplied with chain & D-shackle as pictured.



Code
252007

## Forklift Extension Slippers

- Available in 2 lengths
- The safe working load is measured per pair at 600mm load centre - SWL - 4000kg
- Slippers conform to AS 2359.15
- Finish: Powder coated
- Max Tyne Size: 127mm x 50mm

Code	Dimensions (mm)	Weight Per Pair
252005	1524	49kg
252006	1830	55kg



## ALSTOR™ Tiered Trolleys

- Strong tiered trolleys with many uses
- 250kg load capacity
- Four swivel castors, two with brakes
- Supplied flat-packed for quick and easy assembly

Code	Description	Dimensions (mm)
204100	Alstor™ Trolley; Small 2 Tier	850 x 480 x 950H
204101	Alstor™ Trolley; Medium 2 Tier	1100 x 520 x 950H
204102	Alstor™ Trolley; Small 3 Tier	850 x 480 x 1000H
204103	Alstor™ Trolley; Medium 3 Tier	1100 x 520 x 1020H
204104	Alstor™ Trolley; Small 3 Tier with Enclosed Sides	850 x 480 x 1000H
204105	Alstor™ Trolley; Medium 3 Tier with Enclosed Sides	1100 x 520 x 1020H

ALSTOR™ Trolley; 2 Tier



ALSTOR™ Trolley; 3 Tier



ALSTOR™ Trolley; 3 Tier with enclosed sides



## ALSTOR™ Tool Trolleys

- Strong tool trolleys with many uses
- Four swivel castors, two with brakes
- 250kg load capacity
- Supplied flat-packed for quick and easy assembly

Code	Description	Dimensions (mm)
203000	Alstor™ Tool Trolley; 1 Drawer	850 x 480 x 950H
203001	Alstor™ Tool Trolley; 2 Drawer	850 x 480 x 950H
203002	Alstor™ Tool Trolley; 3 Drawer	850 x 480 x 950H
203003	Alstor™ Tool Trolley; 2 Drawer & Display Board	850 x 480 x 1345H
203004	Alstor™ Tool Trolley; 1 Drawer & Cupboard	850 x 480 x 1000H
203005	Alstor™ Tool Trolley; Fully Enclosed Cupboard	850 x 480 x 950H



203003



203001



203002



203004



203005



203000

## Steel Trolleys

These trolleys are manufactured to high quality standards supported by a 12 month warranty. Features include low maintenance vinyl decktops, sturdy construction, with folding handles on some models for compact storage or transport. Two fixed and two castors enable controlled and easy manoeuvrability.

Code	Capacity	Description	Dimensions (mm)
205000	170kg	Small Platform Trolley with Folding Handle	740L x 480W
205001	300kg	Medium Platform Trolley with Folding Handle	910L x 610W
204000	220kg	Small 2 Tier Trolley	740L x 480W
204001	370kg	Medium 2 Tier Trolley	910L x 610W
204004	170kg	Small 3 Tier Trolley	740L x 480W
204005	300kg	Medium 3 Tier Trolley	910L x 610W
204002	220kg	Small 2 Tier Trolley with Mesh Sides	740L x 480W
204003	370kg	Medium 2 Tier Trolley with Mesh Sides	910L x 610W
205002	500kg	Medium Platform Trolley with Mesh Sides	910L x 610W
205004	500kg	Large Platform Trolley with Fixed Handle	1170L x 760W
205003	500kg	Large Platform Trolley with Folding Handle	1170L x 760W
205007	500kg	Large Platform Trolley with Double Handles	1170L x 760W
205008	500kg	Large Platform Trolley with Mesh Sides	1170L x 760W



205000



205001



204000



204001



204004



204005



204002



204003



205002



205004



205007



205008

## Heavy Duty Utility Cart - Flat Shelf

- Heavy duty plastic carts for warehouses, hospitals, hotels and more
- Perfect for handling bulky items
- Flat shelf top style with removable sides
- All plastic construction - great for cleaning
- Works perfectly as a mobile work surface
- Built in top tray and handle

Code	Description	Dimensions (mm)
204011	3 Tier Small Utility Trolley	960L x 480W x 810H
204013	3 Tier Large Utility Trolley	1100L x 650W x 810H



## Heavy Duty Utility Cart - Lipped Shelf

- Heavy duty plastic carts that are extremely versatile
- Perfect for handling bulky items
- Strong plastic construction that won't rust, chip or dent like metal trolleys
- Easy to clean surface - great for hospitality areas
- Built in top tray and handle

Code	Description	Dimensions (mm)
204007	3 Tier Small Utility Trolley	790L x 435W x 850H
204009	3 Tier Large Utility Trolley	950L x 650W x 850H



## Stock Roll Cage Trolley

- Unique A frame design
- Allows cages to be nested for easy transportation
- Includes quiet roll castors
- 500kg weight capacity

Code	Dimensions (mm)
203500	1730H x 750W x 820L



## Heavy Duty Trolleys

Code	Dimensions (mm)	Handle Height	Capacity
204200	600L x 900W	960mm	340kg
204201	600L x 900W	930mm	340kg
205023	600L x 900W	930mm	340kg
204202	420L x 900W	930mm	220kg
201000	1100L x 420W	1000mm	150kg



204202



201000

Tubs sold separately



204200



204201



205023

## Heavy Duty Platform Trolleys

- Various sizes of heavy duty trolleys to suit your requirements
- Durable long lasting powder coated finish
- 205021 has 6 castors giving it great mobility
- 205022 has a large deck with removable handle

Code	Dimensions (mm)	Handle Height	Load Rating
205020	600L x 900W	920mm	340kg
205021	700L x 1200W	1020mm	520kg
205022	1372L x 685W	960mm	560kg



205020



205022



205021

## Clax Cart

- Australia's favourite office trolley - the only 2 tier trolley that folds completely flat
- Made of injection moulded plastic for longevity
- Collapses easily at the push of a button
- Able to navigate stairs with large rear wheels
- Foot operated parking brake
- Able to be stored upright and flat-packed
- Ideal for sales reps, office duties, schools or hospitality

Code	Dimensions (mm)	Capacity
200007	610L x 460W x 1070H	60kg
200008	Extra Crate	



## X-Cart

- Easily collapsible with the push of a button
- Lightweight and robust frame
- Robust foot pedal break that locks into position when loading and unloading
- Includes removable wheels and a collapsible basket that locks into place

Code	Dimensions (mm)	Capacity
200011	Assembled: 1070H x 600W x 1000L Folded: 105H x 540W x 740L	75kg
200013	Extra Crate	



## Office File Trolley

- Strong all metal construction trolley
- Powder coated finish - built to last
- Perfect for order picking, file transporting or any office tasks

Code	Dimensions (mm)	Capacity
200002	380W x 650L x 650H	220kg





## Large Appliance Trolleys

- Perfect for transporting large furniture
- Safety strap available as an optional extra
- Heavy duty, fully welded, powder coated frame

Code	Handle Height	Wheel Type	Capacity
202004	1540mm	Pneumatic	200kg
202005	1540mm	Stair Climber	220kg



## Multi Purpose Hand Truck - Solid Wheels

- Ideal trolley for cartons, boxes or any general warehouse tasks
- Strong construction and powder coated frame

Code	Handle Height	Capacity
202000	1170mm	180kg



## Multi Purpose Hand Truck - Pneumatic Wheels

- General purpose carton trolley
- Strong tubular powder coated frame
- Puncture proof wheels

Code	Handle Height	Capacity
202001	1255mm	200kg



## Box and Bag Trolley

- Unique easy tilt mechanism to ensure less effort for heavy loads
- Load support system provides full height, flat surface frame for secure support for double box stacks

Code	Handle Height	Capacity
202016	1290mm x 370mm	300kg



## Wheelie Bins

- Made in Australia to high quality standards
- Wide range of colours and sizes available
- Particularly stable due to the position of the wheels
- Quiet running solid rubber tyres

Code	Capacity/Size
255000	80L
255001	120L
255002	140L
255003	240L

Colours Available (All Sizes)



### 240 Litre Spill Kit

Code

240100

#### Includes:

- 6 x 3m absorbent minibooms
- 100 x 410mm x 460mm absorbent pads
- 1 x 10kg MaxSorb premium floorsweep
- 1 x industrial brush and pan set
- 1 x elbow length PVC gloves
- 4 x printed disposal bags
- 1 x 240L labelled wheelie bin
- 1 x product instruction sheet including reorder form



### 120 Litre Spill Kit

Code

240101

#### Includes:

- 3 x 3m absorbent minibooms
- 50 x 410mm x 460mm absorbent pads
- 1 x 10kg MaxSorb premium floorsweep
- 1 x industrial brush and pan set
- 1 x elbow length PVC gloves
- 2 x printed disposal bags
- 1 x 120L labelled wheelie bin
- 1 x product instruction sheet including reorder form



### 80 Litre Spill Kit

Code

240102

#### Includes:

- 4 x 1.2m absorbent minibooms
- 50 x 410mm x 460mm absorbent pads
- 1 x 5kg MaxSorb premium floorsweep
- 1 x industrial brush and pan set
- 1 x elbow length PVC gloves
- 2 x printed disposal bags
- 1 x PVC labelled carry bag
- 1 x product instruction sheet including reorder form



### 40 Litre Spill Kit

Code

240103

#### Includes:

- 1 x 1.2m absorbent minibooms
- 20 x 410mm x 460mm absorbent pads
- 1 x 5kg MaxSorb premium floorsweep
- 1 x elbow length PVC gloves
- 1 x printed disposal bags
- 1 x PVC labelled carry bag
- 1 x product instruction sheet including reorder form



## ALSTOR™ Mobile Kick Stool

- Safe and mobile step stool
- Height: 430mm
- Available in red, black and grey



Code
232006

## Scooter Stool

- Retracting castors
- Height: 380mm



Code	Dimensions (mm)
232000	391 x 391

## Monstar Step

- Height: 375mm
- Four way access
- Durable, safe and robust
- Large area of non-slip tape



Code	Deck Dimensions (mm)
232007	375 x 375

## Team Step-Up

- Height: 370mm
- Heavy duty quality
- Fully fitted with non-slip tape
- Four way access
- Includes rubber feet



Code	Colour	Deck Dimensions (mm)
232001	Yellow	370 x 370
232002	Orange	370 x 370

## Teamstep

- Height: 395mm
- Spring loaded castors
- Rubber rimmed base for security



Code	Colour	Deck Dimensions (mm)
232003	Blue	315 (Top) 480 (Base)
232004	Yellow	315 (Top) 480 (Base)

## Jumbo Teamstep

- Height: 355mm
- Lightweight, durable, one piece construction
- Spring loaded castors
- Rubber rimmed base for security



Code	Dimensions (mm)
232005	375 Ø x 355H

## Trade Series Fibreglass Platform Step Ladder

- Large anti-skid work platform with raised edges – keeps feet inside the platform for greater safety and comfort
- Braced platform and folds flat for storage
- Welded back leg – much greater rigidity, safety and durability
- Optional bolt on handrail and gate – full surround safety

Code	Description	Platform Height (mm)
230020	3 Step	900
230021	4 Step	1200
230022	5 Step	1500
230023	6 Step	1800
230024	7 Step	2100
230025	8 Step	2400
230026	9 Step	2700



## Trade Series Platform Step Ladders

- Much lighter and more user friendly than steel
- Keeps feet inside platform for greater safety and comfort
- One piece smooth operation simply folds out giving a well braced platform and folds flat for storage
- Welded back leg - greater rigidity, durability and safety
- Optional bolt on handrail and gate

Code	Description	Platform Height (mm)
230000	2 Step	600
230001	3 Step	900
230002	4 Step	1200
230003	5 Step	1500
230004	6 Step	1800
230005	7 Step	2100
230006	8 Step	2400
230007	9 Step	2700



## Accessories to suit Trade Series Ladders



Code	Description
230080	Handrail & Safety Gate
230081	Handy Bucket
230082	Spring Loaded Castor Set

## Aluminium Platform Step Ladders

- Wide and stable platform (400mm x 490mm) to ensure added safety when working at heights
- 900mm high hand rail to conform to requirements for temporary work platforms and added security
- Manufactured in Australia and made to Australian Standard AS/NZS 1892.1
- Lightweight and compact for ease of movement around construction sites
- Available in seven sizes to meet your access requirements
- All aluminium welded construction for durability

Code	Description	Platform Height (mm)
230050	2 Step	575
230051	3 Step	860
230052	4 Step	1146
230053	5 Step	1431
230054	6 Step	1716
230055	7 Step	2001
230056	8 Step	2287



## Order Picker Ladders

- Safety gate included as standard
- Rear Tilt-N-Go castors
- Spring loaded castors for ease of manoeuvrability
- Large 600mm x 500mm platform
- Supplied flat-packed with the tools required for assembly

Code	Description	Platform Height (mm)
231030	2 Step	552
231031	3 Step	828
231032	4 Step	1104
231033	5 Step	1381
231034	6 Step	1656
231035	7 Step	1933
231036	8 Step	2208



## Access Platforms

- Ideal for high frequency stock picking applications
- 590mm wide x 800mm deep platform, 900mm high side and rear safety rails with new safety gate supplied as standard
- Fully retracting heavy duty castors
- Provides sturdy platform for warehouse and maintenance applications

Code	Description	Platform Height (mm)	Base Dimensions (mm)
231010	3 Step	828	724W x 1168L
231011	4 Step	1104	764W x 1309L
231012	5 Step	1381	804W x 1451L
231013	6 Step	1656	844W x 1592L
231014	7 Step	1933	884W x 1733L
231015	8 Step	2209	924W x 1875L
231016	10 Step	2761	1003W x 2157L
231017	12 Step	3313	1083W x 2440L
231018	14 Step	3866	1164W x 2723L

Made to Australian Standard AS/NZS 1892.1:1996



## Outdoor Convex Mirror

- Extremely durable weatherproof mirror, suitable for road and pedestrian use
- Comes complete with wall mount and post mount brackets
- High visibility orange visor
- Unbreakable polycarbonate mirror



Code	Dimensions (mm)
241000	450 Ø
241001	600 Ø
241002	800 Ø
241003	1000 Ø

## Indoor Convex Mirror

- Unbreakable polycarbonate mirrors for indoor use
- Comes complete with wall mount and post mount brackets
- Perfect for pedestrian traffic in shops, schools or warehouses



Code	Dimensions (mm)
241004	300 Ø
241005	450 Ø
241006	600 Ø
241007	800 Ø

## Hi-Vis Round Safety Mirror

- Tough shatter proof mirror lens with durable moulded fibreglass backing
- Premium class 1 reflective surface around perimeter
- Suitable for indoor or outdoor applications
- Comes complete with wall mount and post mount brackets



Code	Dimensions (mm)
241008	450 Ø
241009	600 Ø
241010	800 Ø

## Hi-Vis Roundtangular Safety Mirror

- Tough shatter proof mirror lens with durable moulded fibreglass backing
- Premium class 1 reflective surface around perimeter
- Elongated shape allows for view of a wider field
- Comes complete with wall mount and post mount brackets
- Suitable for indoor or outdoor applications

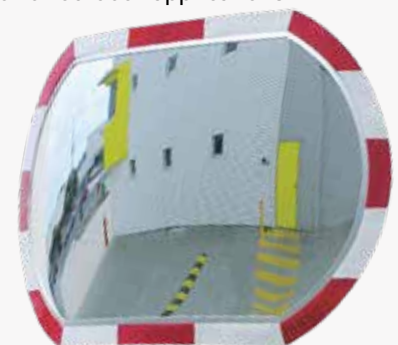

Code	Dimensions (mm)
241011	390 x 570
241012	440 x 640
241013	550 x 830

## Port-a-Guard Expanding Barriers

- Easy solution for denying entry or barricading areas for safety
- Aluminium and high tech plastic construction make them extremely durable
- Perfect for indoor or outdoor use
- Wall mountable or free standing (brackets included)
- Choose powder coated in red/white or yellow/black
- Sign holders, locking castors and wall receivers available as optional extras



Code	Description
242102	3m Barrier; Red/White
242103	3m Barrier; Yellow/Black
242104	6m Barrier; Red/White
242105	6m Barrier; Yellow/Black

## Mezzanine Roll-Over-Gate

- Allows pallets to be safely moved to and from mezzanine floors or loading docks
- Increased safety compared to sliding gates - no pinch points
- Very strong construction - will stand up to forklift mishaps. Complies with Australian Standards
- Alternative sizes also available



Code	Dimensions
WW014	1925W x 1250D x 2300H
WW015	1925W x 1250D x 2650H
WW016	2400W x 1250D x 2300H
WW017	2400W x 1250D x 2650H
WW018	3475W x 1250D x 2300H
WW019	3475W x 1250D x 2650H

## Hi-Vis T-Top Bollards

- Bright orange bollards with reflective tape for visibility
- Wide 6kg base provides stability
- Tough moulded poly construction

Code
242040



## Plastic Safety Chain

- High strength plastic chain to cordon off areas
- Suitable for indoor or outdoor use
- Available in a range of colours



Code	Description
242041	Red 25m Plastic Chain Roll
242042	Red/White 25m Plastic Chain Roll
242043	White 25m Plastic Chain Roll
242044	Yellow 25m Plastic Chain Roll

## Economical Rubber Speed Humps

- Economical alternative for low traffic environments or short term installations
- Built-in bridge design for cables or hoses
- Can be used with or without end caps

Code	Description	Colour
243000	250mm Hump	Black
243001	250mm Hump	Yellow
243002	250mm End Pair	Black



## Steel Speed Humps

- Super strong chassis construction with floor plate and bolt fixing
- Ideal for seriously heavy duty use including B-doubles
- Perfect for transport depots or factories
- Built-in bridge design for cables or hoses
- Available in 1000mm or 500mm lengths

Code	Description	Colour
243010	500mm Hump	Black/Yellow
WW001	1000mm Hump	Black/Yellow
243011	End Pair	Yellow



## Bollards

- Light duty bollards that are great value without compromising quality
- Available as bolt-down or inground
- Perfect for zoning off areas or pedestrian management
- Fully welded heavy duty steel base plates

Code	Dimensions (mm)	Description
612002	1000H x 63 Ø	Inground
612003	1200H x 140 Ø	Inground
612004	1000H x 63 Ø	Bolt Down
612005	1200H x 140 Ø	Bolt Down





# Office & Retail Solutions

- Office Storage
- Whiteboards and Pinboards
- Office Partitions
- Office Furniture
- Reception Furniture
- Office Chairs
- Ergonomic Accessories



# ALSTOR™ Tambour Door Cabinets



- Side opening tambour door cabinets are designed to maximise storage space
- Doors slide back into the cabinet to maximise space in the office
- Fully lockable
- Magnetic slam rail keeps door closed
- Full range of accessories to suit
- Available in black or white

Code	Dimensions (mm)
310100	1016H x 900W x 473D
310101	1200H x 900W x 473D
310102	1980H x 900W x 473D
310103	1016H x 1200W x 473D
310104	1200H x 1200W x 473D
310105	1980H x 1200W x 473D
310106	Shelf to suit 900W Unit
310107	Shelf to suit 1200W Unit



## Stronghold Tambour Door Cabinet

- Strong all steel construction tambour door cabinets
- Choose either silver, grey or white or can be powder coated to your chosen colour
- Large range of sizes available
- Full length magnetic catch keeps door closed

Code	Dimensions (mm)	Shelf Levels
310130	680H x 900W x 500D	1
310131	1020H x 900W x 500D	2
310132	1200H x 900W x 500D	2
310133	1340H x 900W x 500D	2
310134	1980H x 900W x 500D	4
310135	680H x 1200W x 500D	1
310136	1020H x 1200W x 500D	2
310137	1200H x 1200W x 500D	2
310138	1340H x 1200W x 500D	2
310139	1980H x 1200W x 500D	4
310150	Shelf to suit 900W Unit	
310151	Shelf to suit 1200W Unit	

## Tambour Cabinet Accessories

### Accessories To Suit ALSTOR™ Tambour Door Cabinets

Code	Dimensions
310116	Roll Out Reference Shelf to Suit 900W
310117	Roll Out Reference Shelf to Suit 1200W
310118	Roll Out Suspension Filing Frame to 900W
310119	Roll Out Suspension Filing Frame to 1200W
310115	Clip On Divider; 175mm High
310110	Planter Box To Suit 900W
310111	Planter Box To Suit 1200W

### Accessories To Suit Stronghold Tambour Door Cabinets

Code	Dimensions
310150	Roll Out Reference Shelf to Suit 900W
310151	Roll Out Reference Shelf to Suit 1200W
310154	Roll Out Suspension Filing Frame to 900W
310155	Roll Out Suspension Filing Frame to 1200W
310156	Shelf Divider; 500mm Deep
310157	Planter Box To Suit 900W
310158	Planter Box To Suit 1200W



## Endurostor Cabinets

- An economical solution that doesn't compromise on quality
- Ideal for a large range of storage applications
- 3 point locking system with key
- Adjustable shelves
- Colours: (LG) Grey | (GR) Graphite Ripple

NOTE: add colour abbreviation to end of code when ordering

Code	Dimensions (mm)
310092	900H x 900W x 450D
310091	1850H x 900W x 450D
310002	Extra shelves to suit 900 x 450mm



## Stronghold Storage Cabinets

- An extremely versatile cabinet with a wide range of applications
- Great for files, stationery, general and small parts storage
- 3 point locking system with key
- 3 adjustable shelves (4 storage levels)
- Colours: (B) Beige | (LG) Light Grey | (GR) Graphite Ripple

NOTE: add colour abbreviation to end of code when ordering

Code	Dimensions (mm)
310014	915H x 900W x 455D
310015	915H x 900W x 600D
310010	1840H x 900W x 455D
310011	2100H x 900W x 455D
310012	2100H x 900W x 600D
310013	2100H x 1150W x 600D
310020	900 x 455 Extra Shelf
310021	900 x 600 Extra Shelf



## ALSTOR™ Utility Cupboard

- Flush handle locking with foldable keys
- Concealed hinges without brackets
- Coat hanger rack
- 4 shelf levels
- Available in grey only

Code	Dimensions (mm)
310071	1830H x 915W x 457D



## Sloping Top Cabinets

- Integrated sloping top
- Strong all steel construction
- Fully welded with a powder coated finish
- Levelling feet
- 3 point locking system
- Reinforced doors
- 120kg shelf load capacity
- 4 adjustable shelves

Code	Dimensions (mm)
310018	2100H x 900W x 455D



## ALSTOR™ Filing Cabinets

- Available in 2, 3 or 4 drawer options
- 100% extension opening, maximising filing space
- Anti-tilt locking device
- Colours: (BR) Black Ripple, (GR) Graphite Ripple (SG) Silver Grey, (W) White

NOTE: add colour abbreviation to end of code when ordering

Code	Description	Dimensions (mm)
314000	2 Drawer	460W x 620D x 705H
314001	3 Drawer	460W x 620D x 1016H
314002	4 Drawer	460W x 620D x 1321H



## ALSTOR™ Lateral Filing Cabinets

- Perfect for high volume filing
- Files are stored side by side through length of drawer, allowing maximum filing space
- Long wide tops can be used for additional storage areas
- 100% extension opening maximising filing space
- High sides provide additional strength
- Cross bars in each drawer facilitate A4 or foolscap filing
- Available in white only

Code	Description	Dimensions (mm)
314020	2 Drawer	705H x 900W x 473D
314021	3 Drawer	1016H x 900W x 473D
314022	4 Drawer	1341H x 900W x 473D



## Mobile Storage Units

- Compact storage saves costly floor space
- Reduce time spent finding and filing records
- Configured to suit your requirements
- Units are relocatable
- Range of colours available

## Free Track Mobile Storage Systems

Free Track Mobile Storage Units are an economical storage system for the office, archive area or the warehouse. Free Track is available in longitudinal (cross aisle) or transverse style to suit storage space and accessibility requirements.

Free Track Mobile Storage Units are available in standard configurations or can be designed to suit specific requirements. Free Track Mobile Storage Units are supplied to suit specific needs by quotation only. Please contact our sales team for assistance.

DEPTHS (mm)	WIDTHS (mm)	HEIGHTS (mm)
300, 400	900, 1200	1875, 2175

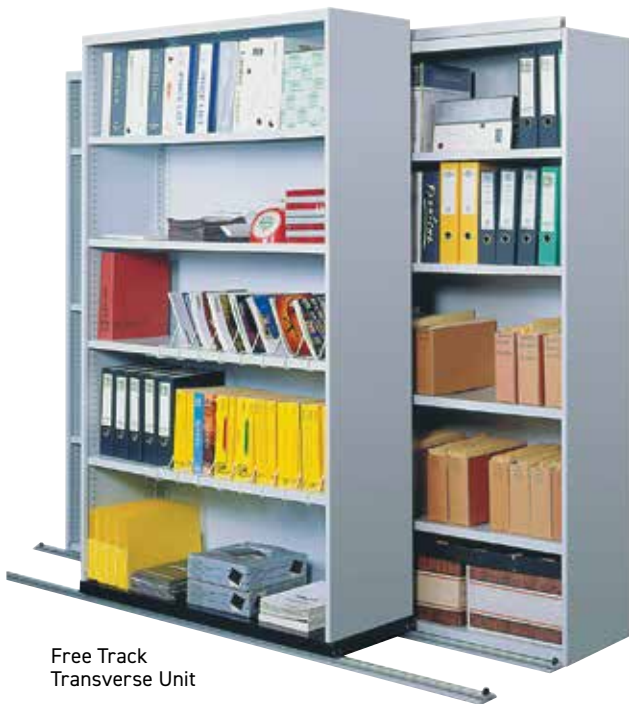

Free Track Transverse Unit



Standard Free Track Longitudinal (Cross Aisle) Unit

- Free of any fixed or standard lengths. Just lay track to suit the space
- The low profile on-floor aluminium tracking and precision bearing load wheel system allows for easy movement of shelving units
- Shelving is fitted to base trolleys with aluminium wheel carriers for reduced weight and increased rigidity
- Safety is ensured by the overhead stabiliser system tying the units together as they slide
- As the tracks are not fastened to the floor, there is no damage to floor coverings
- Free track units can be added to and reorganised
- Units can be easily relocated
- Range of accessories available to suit your requirements
- Range of colours available
- 4, 6, 8 or 10 bay units available

## Steel Storage Lockers



### Colour Swatches



All colour samples shown are for illustration purposes only. Actual product may vary.

- Fully welded construction
- Two tier units include hanging rail
- Cam lock system with 2 keys per door
- Single tier units include 1 shelf and hanging rail
- Available in a wide range of colours

Code	Description	Dimensions (mm)
311600	Single Tier	1800H x 300W x 450D
311601	Two Tier	1800H x 300W x 450D
311602	Three Tier	1800H x 300W x 450D
311603	Four Tier	1800H x 300W x 450D
311604	Five Tier	1800H x 300W x 450D
311605	Six Tier	1800H x 300W x 450D
311606	Eight Tier	1800H x 300W x 450D
311607	Ten Tier	1800H x 300W x 450D
311608	Twelve Tier	1800H x 300W x 450D
311609	Single Tier	1800H x 380W x 450D
311610	Two Tier	1800H x 380W x 450D
311611	Three Tier	1800H x 380W x 450D
311612	Four Tier	1800H x 380W x 450D
311613	Five Tier	1800H x 380W x 450D
311614	Six Tier	1800H x 380W x 450D
311615	Eight Tier	1800H x 380W x 450D
311616	Ten Tier	1800H x 380W x 450D
311617	Twelve Tier	1800H x 380W x 450D

## Laptop Lockers

- Australian made with a lifetime warranty
- Rear ventilation holes
- Secure single point lock mechanism
- Available in a wide range of colours



Code	Description	Dimensions (mm)
311303	Eight Tier	300W x 1800H x 450D
311304	Ten Tier	300W x 1800H x 450D
311305	Twelve Tier	300W x 1800H x 450D
311306	Eight Tier	380W x 1800H x 450D
311307	Ten Tier	380W x 1800H x 450D
311308	Twelve Tier	380W x 1800H x 450D

## ALSTOR™ Storage Lockers

- Cam lock system complete with two foldable keys per door
- Complete with air ventilation holes and index name card holders
- Ideal for gyms, schools, offices, workshops, hospitals, etc.
- Dimensions: 1830H x 380W x 457mmD
- Colour: Silver Grey



Code	Description
311000	Single Tier
311001	Two Tier
311002	Three Tier
311003	Four Tier
311004	Six Tier

## Melamine Lockers

- Stylish melamine lockers
- 300W x 450D x 1800mmH

Code	Description
311470	Single Tier
311471	Two Tier
311472	Three Tier
311473	Four Tier
311474	Two Step Door



## Metal Pigeon Hole

- Compartment size: 155H x 245W x 375mmD
- Fully welded construction
- Standard lock system: flush lock with 2 keys (units with doors only)
- Available in a wide range of colours and finishes
- Lifetime warranty

Code	Description	Dimensions (mm)
310304	20 Compartment	970H x 1040W x 385D
310305	20 Compartment with Doors	970H x 1040W x 385D
310306	40 Compartment	1840H x 1040W x 385D
310307	40 Compartment with Doors	1840H x 1040W x 385D

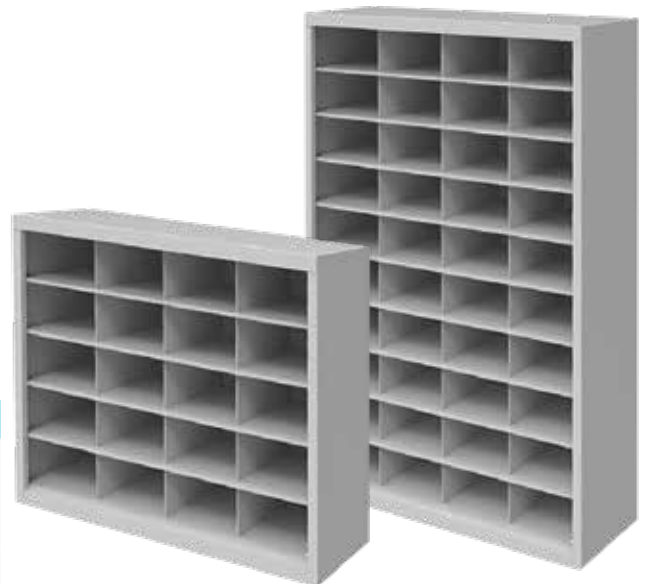

## Timber Pigeon Hole

- All melamine construction
- Available in a range of colours

Code	Description	Dimensions (mm)
310308	27 Compartment	1800H x 900W x 330D



## Mobile Melamine Tote Box Trolleys

- Strong melamine trolleys made to order
- Customisable to your school colours
- Heavy duty lockable castors

Code	Dimensions (mm)	Tubs
300100	540W x 420D x 886H	5
300101	820W x 420D x 886H	10
300102	1216W x 420D x 886H	15



## Mobile Metal Frame Tote Trolleys

- Fantastic addition to any art rooms, classrooms or home economic areas
- Heavy duty lockable castors
- 18mm melamine top

Code	Dimensions (mm)	Tubs
300000	540W x 420D x 873H	5
300001	992W x 420D x 873H	10
300002	1450W x 420D x 873H	15



## Lunar Metal Mobile Caddy

- Mobile storage caddy in heavy duty steel construction
- Tambour door cupboard with 1 adjustable shelf
- Master key lockable 2 drawers and 1 file drawer
- Pencil tray in top drawer
- Dimensions: 900W x 500D x 595mmH

Code	Description	Colour
314103	Left Hand Door	White
314104	Right Hand Door	White



## Lunar Metal Mobile Pedestals

- Mobile drawer pedestals in strong steel construction
- Master key lockable 2 drawers and 1 file drawer
- Pencil tray and divider in top drawer
- Compact low profile allows it to fit under most desks
- Dimensions: 390W x 500D x 595mmH

Code	Colour
314100	White
314101	Silver
314102	Charcoal





## Wallmount Whiteboards

- Hardwearing magnetic surface
- Aluminium frame with concealed fixings
- Supplied with pen tray
- Commercial - 8 year surface guarantee
- Porcelain - 25 year surface guarantee



Custom sizes available

COMMERCIAL	
Code	Dimensions (mm)
321040	600 x 450
321041	900 x 600
321042	900 x 900
321043	1200 x 900
321044	1200 x 1200
321045	1500 x 900
321046	1500 x 1200
321047	1800 x 900
321048	1800 x 1200
321049	2100 x 1200
321050	2400 x 1200
321051	3000 x 1200

PORCELAIN	
Code	Dimensions (mm)
321055	900 x 600
321056	900 x 900
321057	1200 x 900
321058	1200 x 1200
321059	1500 x 900
321060	1500 x 1200
321061	1800 x 900
321062	1800 x 1200
321063	2100 x 1200
321064	2400 x 1200
321065	3000 X 1200
321066	3600 x 1200

## Mobile Whiteboards

- Double sided rotating whiteboard
- Magnetic surface with 8 year guarantee
- Locking castors
- Built in pen tray
- Strong powder coated steel design
- Board can be locked into different writing angles

Code	Dimensions (mm)
321100	1200 x 900
321102	1500 x 900
321103	1500 x 1200
321104	1800 x 1200



## Electronic Whiteboards

- Two screen colour electronic copyboard
- One touch colour print or save to USB
- Simple to use - plug & play - no software to install!
- Ink jet printer supplied
- Floor stand is an optional extra

Code	Dimensions (mm)
321182	1300 x 910
321183	1800 x 910



## Lumiere Magnetic Glassboards

- Modern alternative to traditional whiteboards for when a cutting edge look is required
- Tempered frameless non-porous glass
- Works well with dry erase markers
- Chrome fixtures float the board 20mm off the wall
- Lifetime warranty

Many sizes available – ask us for options!



## Glass Fronted Notice Boards

- Australian made high quality notice board
- Easy glide nylon ball bearing track mechanism
- Comes with clear safety 6.3mm glass doors (polycarbonate doors available on request)
- Choose either cork, velour or felt backing

Code	Dimensions (mm)
321531	1200 x 900
321532	1500 x 900
321533	1800 x 900
321536	1800 x 1200
321537	2400 x 1200



## TX Notice Cases

- Unique weather resistant design with internal rubber seal
- No visible hinges – internal pivoting design
- Aluminium frame in satin silver finish
- Back board is bulletin cork board



Code	Dimensions (mm)
321600	590 x 760
321601	590 x 1080
321602	820 x 1080
321603	1050 x 1080

## Corkboard

- Natural tones of cork to suit any office décor
- 100% natural cork over bioboard provides an environmentally friendly product
- Aluminium frame and concealed wall fixings

Code	Dimensions (mm)
321419	900W x 600H
321420	900W x 900H
321421	1200W x 900H
321422	1200W x 1200H
321423	1500W x 900H
321424	1500W x 1200H
321425	1800W x 1200H
321426	2400W x 1200H



## Standard Framed Pinboards

- High quality smooth velour boards
- Low maintenance - ideal for office or classrooms
- Works well with hook and loop or pins
- Made in Australia - available in a wide range of colours
- Custom sizes available



Code	Dimensions (mm)
321350	450 x 600
321352	900 x 600
321353	900 x 900
321354	1200 x 900
321355	1200 x 1200
321356	1500 x 900
321357	1500 x 1200
321358	1800 x 900
321359	1800 x 1200
321362	2400 x 900
321363	2400 x 1200
321364	2700 x 1200
321365	3000 x 1200



[View the full colour range](#)

## Unwrapped Pinboards

- Highly popular unframed wrapped over the edge pinboards
- No aluminium frame - secured to environmentally friendly bioboard backing
- Available in a large range of colours & sizes
- Stainless steel screw cap fixing included (kit includes fixing to gyprock or brick)

Code	Dimensions (mm)
321320	900 x 600
321321	900 x 900
321322	1200 x 900
321326	1800 x 900
321327	1800 x 1200
321328	2400 x 1200



[View the full colour range](#)





## Axis Desking

- Very versatile range for offices - desking, storage and height adjustable all available to match
- Short lead time - quick and easy to install
- Ideal for both individual offices or concentrated work areas
- 10 year guarantee
- Frames finished in gloss white powder coat
- Manual and electric height adjustable options also available

### Standard Features:

- Height adjustable - 80mm height adjustment in each foot
- Available with modesties
- 50mm x 50mm square end frames with flush ground weld
- 3 compatible screens available
- Fixed height 720mm
- 25mm worksurfaces finished in white melamine on E0 grade substrate with matching PVC edge

### Screen Options:

- Studio 50 (as seen on page 80)
- Breathe 22mm
- Split 22mm





Electric height adjustable workstation with Studio 50 screens

## Axis 90 Degree Workstation

### Options:

Single - Workstation | Shared - Pod  
 1800L x 1800W x 600D mm  
 1800L x 1800W x 750D mm

### POSSIBLE CONFIGURATIONS

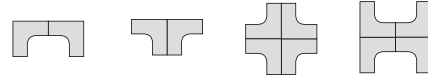

Manual height adjustable workstation with Studio 50 screens  
 \*available as standard

## Axis 120 Degree Workstation

### Options:

Single - Workstation | Shared - Pod  
 1200L x 1200W /600mmD  
 1200L x 1200W/750mmD

### POSSIBLE CONFIGURATIONS



Standard workstation with Studio 50 screens

## Axis Straightline Desk

### Options:

Single - Desk | Shared - Straightline or Back to Back  
 1200L x 600mmD  
 1200L x 750mmD  
 1500L x 600mmD  
 1500L x 750mmD  
 1500L x 800mmD (scallop top)  
 1800L x 600mmD  
 1800L x 750mmD  
 1800L x 800mmD (scallop top)

### POSSIBLE CONFIGURATIONS



Standard (90 degree)



Manual (120 degree)



Electric (Straightline)



## Anvil Desking

Anvil frame systems give your office spaces a refreshing image that will encourage freedom of thought and inspired decision making.

- Triangular look leg - eye catching design
- Frames available in gloss white or matte black powder coat
- Extensive range of sizes and options available
- 10 year guarantee

### Standard Features:

- Available with modesties on single desks
- 50mm x 50mm triangle end frames with flush ground weld
- 3 compatible screens available
- Fixed height 715mm
- 25mm worksurfaces finished in white melamine on E0 grade substrate with matching PVC edge

### Screen Options:

- Studio 50 (as seen on page 80)
- Breathe 22mm
- Split 22mm





Shown with Split Screens in Black E-panel

## Anvil 90 Degree Workstation

### Options:

Single - Workstation

Shared - Pod

1800L x 1800W x 600D mm

1800L x 1800W x 750D mm



### POSSIBLE CONFIGURATIONS

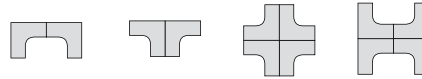

## Anvil 120 Degrees Workstation

### Options:

Single - Workstation

Shared - Pod

1200L x 1200W /600mmD



Shown with Split Screens in translucent PVC and Red E-panel

### POSSIBLE CONFIGURATIONS



## Anvil Straightline Desk

### Options:

Single - Desk

Shared - Straightline or Back to Back

1200L x 600mmD

1200L x 750mmD

1500L x 600mmD

1500L x 750mmD

1500L x 800mmD (scallop top)

1800L x 600mmD

1800L x 750mmD

1800L x 800mmD (scallop top)



Shown with Split Screens in Black E-panel

### POSSIBLE CONFIGURATIONS



## Rapid Screens System

- Rapid Screens are an off the shelf system with multiple configurations
- Choose either blue or grey pinnable screen fabrics
- Wide range of accessories available
- 5 year warranty



### Sizes Available:

1250H x 750W	1650H x 750W
1250H x 1200W	1650H x 1200W
1250H x 1500W	1650H x 1500W
1250H x 1800W	1650H x 1800W

## Rapid Screens Partition Accessories



## Studio 50 Screen System

- Lightweight easy to manage screen system that effortlessly slides and automatically locks into position
- Can be covered in any fabric - choose from our range or supply your own
- Frames available in white, black or silver powder coat
- Available as desk mounted, mobile, freestanding or integrated
- 10 year guarantee



See the full colour range online





## Mobile Partitions

- Double sided pinnable screen
- Tough powder coated frame
- Durable mobile locking castors
- Pinboard size – 1800 x 1000mm

Code	Colour
320070	Lime
320071	Sand
320072	Koala



## Partitions

- Use as room dividers, noise barriers or to create a private space
- Range of joiners available
- Partitions come standard with feet
- Available in a range of 40 colours



Cross Joiner



L Joiner



Straight Joiner



T Joiner

WIDTHS (mm)	HEIGHTS (mm)
900, 1200, 1500, 1800, 2000	1200, 1500, 1800, 2000



## Boost+ Height Adjustable Desk

- Dual motor on standard desks, triple motor on workstations
- 120kg weight lifting capacity on standard desks
- 140kg weight lifting capacity on workstations
- Smooth and quiet adjustment at 38mm per second
- Anti-collision and anti-tilt safety features
- Digital controller with 3 programmable heights

Code	Description	Dimensions (mm)
335010	Standard Desk	1200W x 750D x 620-1270H
335011	Standard Desk	1500W x 750D x 620-1270H
335012	Standard Desk	1800W x 750D x 620-1270H
335050	Workstation	1800 x 1800 x 620-1270H
335051	Workstation	1800 x 1500 x 620-1270H
335052	Workstation	1500 x 1500 x 620-1270H



## Drummond Electric Height Adjustable Desk

- Stylish, modern and open frame design
- Choose tops in either warm white or beech
- Available in black, white or silver powder coated frame
- Load Rating - 80 kg
- 5 year warranty

Code	Description	Dimensions (mm)
335000	Standard Desk	1200 x 700 x 690-1185mm
335001	Standard Desk	1500 x 700 x 690-1185mm
335002	Standard Desk	1800 x 700 x 690-1185mm



## Electric Desk Riser

- Height adjustable solution to sit on top of your existing desk
- Height adjusts from 120 - 500mm
- Quiet concealed motor - clean compact design
- Choose either black or white
- Built in cable management and hole for monitor arm

Code	Dimensions (mm)
322233	880W x 415L
322234	950W x 415L



## Manual Height Adjustable Desk

- Adjustable desk height to suit sitting or standing position
- Universal crank handle that folds away when not in use
- Available in bright white, warm white or beech tops
- Load Rating - 100kg

Code	Dimensions (mm)
340031	1200 x 750 x 715-1015
340030	1500 x 750 x 715-1015
340032	1800 x 750 x 715-1015



## Manual Desk Riser

- Adjustable solution to sit on top of your existing desk
- Gas spring offers smooth and even height adjustment
- 15 height adjustment levels
- Includes hole for monitor arm, tablet or phone holder and cable tie for leads or cables
- Choose either black or white

Code	Dimensions (mm)
322230	680W x 590L
322231	890W x 590L



## Height Adjustable Student Desk

- 18mm top with rounded corners
- 7 levels tech height adjustable (560 – 800mmH)
- Anti-scratch zinc coated legs
- Plastic storage tubs with rubber stoppers

Code	Dimensions (mm)	Tubs
340500	600W x 600D	1
340501	1200W x 600D	2



# Elite Office Furniture

- Proudly Australian made
- Customise to your choice
- Available in any laminate colour
- Excellent quality, boasting a 7 year warranty
- 25mm construction



See the Elite range and colours online

Some colour combinations may be discontinued.



### Desk

Code	Dimensions (mm)
334000	1500 x 750 x 720H
334001	1800 x 750 x 720H
334002	2100 x 750 x 720H
334003	2400 x 750 x 720H
334004	1500 x 900 x 720H
334005	1800 x 900 x 720H
334006	2100 x 900 x 720H
334007	2400 x 900 x 720H



### Bow Front Desk

Code	Dimensions (mm)
334012	1800 x 900 x 720H
334013	2100 x 900 x 720H



### Splay Workstation

Code	Dimensions (mm)
334020	1800 x 1800 x 600D
334021	2100 x 1800 x 600D
334022	2400 x 1800 x 600D
334023	2100 x 2100 x 600D
334024	2400 x 2100 x 600D
334025	2400 x 2400 x 600D



### Radial Workstation

Code	Dimensions (mm)
334026	1800 x 1800 x 600
334027	2100 x 1800 x 600
334028	2400 x 1800 x 600
334029	2100 x 2100 x 600
334030	2400 x 2100 x 600
334031	2400 x 2400 x 600



### Full Door Storage Cabinet

Code	Dimensions (mm)
334720	900 x 900 x 450
334721	1800 x 900 x 450

### Half Door Storage Cabinet

Code	Dimensions (mm)
334722	1800 x 900 x 450



### Sliding Door Buffet

Code	Dimensions (mm)
334700	900 x 450 x 720H
334701	1200 x 450 x 720H
334702	1500 x 450 x 720H
334703	1800 x 450 x 720H
334704	2100 x 450 x 720H
334705	2400 x 450 x 720H

Also available in 600mmD & 900mmH

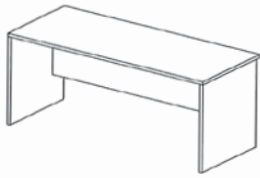

**Desk**

Depth: 750 or 900  
Height: All 720  
Lengths: 1350, 1500, 1800, 2100

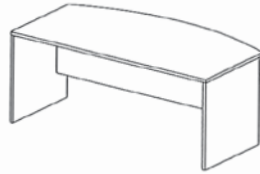

**Executive Desk**

Depth: 750 or 900  
Height: All 720  
Lengths: 1800, 2100

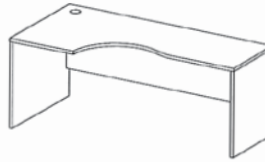

**Radial Desk**

Depth: 900 (Left), 750 (Right)  
Height: All 720  
Lengths: 1800, 2100

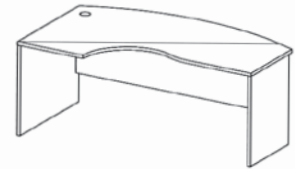

**Executive Radial Desk**

Depth: 900 (Left), 750 (Right)  
Height: All 720  
Lengths: 1800, 2100

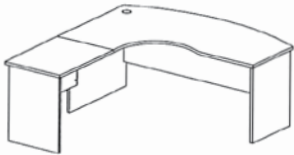

**Executive Radial Workstation**

Depth: 750  
Height: All 720  
Lengths: 1800, 2100, 2400  
Available as: Left and Right

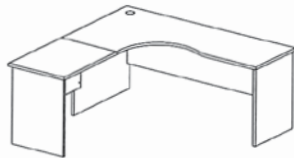

**Radial Workstation**

Depth: 750  
Height: All 720  
Lengths: 1800, 2100, 2400  
Available as: Left and Right

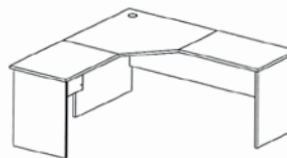

**Splay Workstation**

Depth: 750  
Height: All 720  
Lengths: 1800, 2100, 2400  
Available as: Left and Right

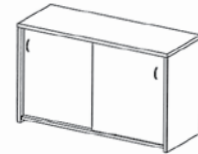

**Buffet**

Depth: 457 or 600  
Height: 720 or 900  
Lengths: 900, 1200, 1500, 1800, 2100

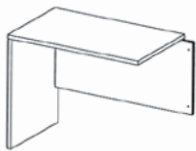

**Standard Return**

Depth: 560  
Height: 720  
Lengths: 900, 1200

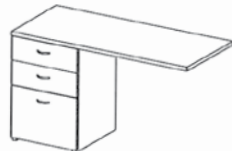

**Universal Return**

Depth: 560  
Height: 720  
Lengths: 900, 1200, 1500



**Universal PC Return**

Depth: 560  
Height: 720  
Lengths: 900, 1200, 1500



**Mobile Pedestal**

Depth: 457  
Height: 675  
Available as: Twin File, 2 Drawers and 1 File, 4 Drawers



**Filing Banks**

Depth: 457  
Height: 720  
Lengths: 923, 1366, 1810  
Available as: 4, 6 or 8 Drawer Combination

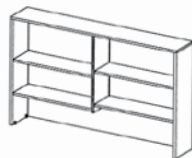

**Bookcase Hutch**

Depth: 310  
Height: All 1080  
Lengths: 900, 1200, 1500, 1800, 2100



**Bookcase**

Depth: 310  
Height: 900, 1200, 1800, 2100  
Length: 900



**Utility Cupboard**

Depth: 457  
Height: 1800  
Length: 900

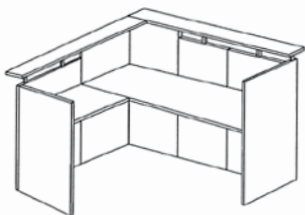

**Finesse Reception**

Depth: 750/600  
Height: 1092  
Lengths: From 2100 x 1800 to 3000 x 3000

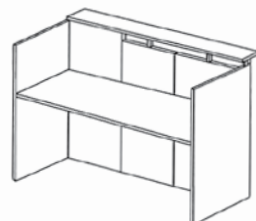

**Solo 2 Reception**

Depth: 750  
Height: 1092  
Lengths: From 1800 to 2400

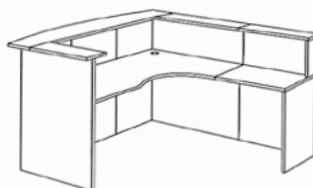

**Radial Reception**

Depth: 750/600  
Height: 1092  
Lengths: From 1800 x 1800 to 2400 x 2400



**Oval Boardroom**

Depth: 1050, 1200, 1350  
Height: 720  
Lengths: 1500, 1800, 2100, 2400

# Deluxe Office Furniture



- 5 year warranty
- High quality
- Quick ship option
- 25mm construction
- Supplied flat-packed for quick & easy assembly
- Installation service available
- **Colours:**  
 Beech/Iron Grey (BI)  
 Cherry/Iron Grey (CI)  
 Redwood/Iron Grey (RI)  
 Note: Add colour abbreviation to end of code when ordering

Some colour combinations may be discontinued.



**Colours Available:** Beech/Iron Grey Cherry/Iron Grey Redwood/Iron Grey



**Desk**

Code	Dimensions (mm)
330000	1800W x 900D x 720H
330001	1500W x 900D x 720H
330002	1500W x 750D x 720H



**Bow Front Desk**

Code	Dimensions (mm)
330015	1800W x 900/750D x 720H
330016	2100W x 900/750D x 720H



**P End Desk**

Code	Dimensions (mm)
330010 LH	2100W x 900/1050D x 720H
330011 RH	2100W x 900/1050D x 720H



**2 Piece Workstation**

Code	Dimensions (mm)
330200 LH	1800W x 1800W x 750D
330201 RH	1800W x 1800W x 750D



**Mobile Pedestal**

Code	Description
330605	2 Drawers / 1 File
330606	2 Files
330607	4 Drawers



**Fixed Pedestal**

Code	Description
330600	1 Drawer / 1 File
330601	3 Drawers



### Desk Return

Code	Dimensions (mm)
330020	900W x 600D x 720H
330021	900W x 450D x 720H



### Desk Hob

Code	Dimensions (mm)
330709	1800W x 300D x 425H
330710	1500W x 300D x 425H

### Bow Front Hob (Not pictured)

Code	Dimensions (mm)
330711	2100W x 300D x 425H



### Deluxe Bookcase

Code	Dimensions (mm)
330733	1800H x 900W x 320D
330732	1500H x 900W x 320D
330731	1200H x 900W x 320D
330730	900H x 900W x 320D



### Filing Cabinet

Code	Dimensions (mm)
330620	468W x 510D x 1295H



### Full Door Stationery Cupboard

Code	Dimensions (mm)
330720	900W x 450D x 1800H

### Half Door Stationery Cupboard

Code	Dimensions (mm)
330721	900W x 450D x 1800H



### Buffet Sliding Door

Code	Dimensions (mm)
330700	1800W x 450D x 720H
330701	1500W x 450D x 720H



### Buffet Hinge Door

Code	Dimensions (mm)
330702	900W x 450D x 720H



### Hutch

Code	Dimensions (mm)
330705	1800W x 325D x 1080H
330706	1500W x 325D x 1080H
330707	900W x 325D x 1080H

# Rapid Worker Office Furniture



- Quick ship economy range
- 3 year warranty
- 25mm top x 18mm sides
- Supplied flat-packed for quick & easy assembly
- Installation service available

**Colours:**

Beech/Ironstone (BI)  
Cherry/Ironstone (CI)

Note: Add colour abbreviation to end of code when ordering

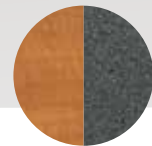
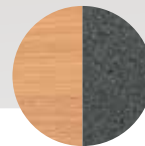

Some colour combinations may be discontinued.

Colours Available: Beech/Ironstone

Cherry/Ironstone



Note: Drawers not included.

**Desk**

Code	Dimensions (mm)
331000	1800 x 900
331001	1800 x 750
331002	1500 x 750
331003	1200 x 600



Note: Drawers not included.

**3 Piece Workstation**

Code	Dimensions (mm)
331100	1500 x 1500 x 600
331101	1800 x 1500 x 600
331102	1800 x 1800 x 600
331103	2100 x 1500 x 600
331104	2100 x 1800 x 600
331105	2100 x 2100 x 600



**Mobile Pedestal**

Code	Dimensions (mm)	Description
331302	690 x 456 x 477	2 Drawers / 1 File
331303	690 x 456 x 477	2 Files
331304	690 x 456 x 477	4 Drawers



**Desk Hob**

Code	Dimensions (mm)
331130	1800L x 350D x 400H
331131	1500L x 350D x 400H



**Desk Return**

Code	Dimensions (mm)
331020	900 x 450
331021	900 x 600
331022	1200 x 600





### Fixed Pedestal

Code	Description
331300	1 Drawer /1 File
331301	3 Drawers



### Filing Cabinet

Code	Description
331321	3 Drawers
331320	4 Drawers



### Lockable Cupboard

Code	Dimensions (mm)
331420	1800H x 900W x 450D

Complete with 3 shelves.



### Bookcase

Code	Dimensions (mm)
331412	1800H x 900 x 315
331411	1200H x 900 x 315
331410	900H x 900 x 315



### Lockable Wall Unit

Code	Dimensions (mm)
331421	1800H x 900 x 450



### Sliding Door Credenza

Code	Dimensions (mm)
331422	1800 x 450 x 730H
331423	1500 x 450 x 730H
331424	1200 x 450 x 730H



### Round Table

Code	Dimensions (mm)
338100	900 Ø
338101	1200 Ø



### Hutch

Code	Dimensions (mm)
331402	1200L x 315D x 1070H
331401	1500L x 315D x 1070H
331400	1800L x 315D x 1070H



### Pigeon Hole Unit

Code	Dimensions (mm)
331435	1040W x 1040H x 380D

# Rapid Span Office Furniture



- Contemporary clean look
- Choose tops in either beech, white or natural oak
- Available in black, silver or white powder coated frames
- Perforated metal modesty panel
- 5 year warranty
- Supplied flat-packed for easy assembly

Code	Description	Dimensions (mm)
332015	Standard Desk	1200 x 700
332016	Standard Desk	1500 x 700
332017	Standard Desk	1800 x 700
332020	Workstation	1500 x 1500 x 700
332021	Workstation	1800 x 1200 x 700
332022	Workstation	1800 x 1500 x 700
332023	Workstation	1800 x 1800 x 700
332100	3 Drawer Mobile Pedestal	690 x 447 x 465
332101	Credenza	1200 x 730 x 450
332102	Credenza	1800 x 730 x 450
332105	Bookcase	1200 x 900 x 315
332106	Bookcase	1800 x 900 x 315
332108	Cupboard	1800 x 900 x 450
332109	Hutch	1200 x 315 x 1070
332152	Round Table	900 Ø
332153	Round Table	1200 Ø



Desk



3 Drawer Mobile Pedestal



Bookcase



Workstation



Hutch



Cupboard



Round Table



Credenza



## Deluxe Infinity Office Furniture



**Desk with Screen**

Code	Dimensions (mm)
333230	1200 x 750 x 730
333231	1500 x 750 x 730
333232	1800 x 750 x 730



**Desk**

Code	Dimensions (mm)
333200	1200 x 750 x 730
333201	1500 x 750 x 730
333202	1800 x 750 x 730



**Corner Workstation**

Code	Dimensions (mm)
333240	1800 x 1500
333241	1800 x 1800



**Bookcase**

Code	Dimensions (mm)
333280	900 x 315 x 1200
333281	900 x 315 x 1800

Finishes; Natural Oak or Natural White



**Swing Door Cupboards**

Code	Description	Dimensions (mm)
333290	2 Door	900 x 600 x 730
333291	3 Door	1200 x 450 x 730
333292	3 Door	1500 x 450 x 730
333293	4 Door	1800 x 450 x 730

Finishes; Natural Oak or Natural White

**Top finishes;**



Natural Oak



Natural White

**Leg and frame finishes;**

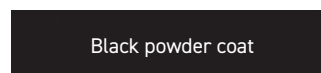

Black powder coat

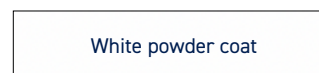

White powder coat

## Geo Executive Desks

- Minimalist design for a contemporary office
- Maintain an open airy workspace with an uncluttered look
- Built in storage includes 1 x drawer, 1 x file, 1 x open shelf unit
- Available in a wide range of colour options



Geo Plaza



Geo Leto



Geo Scope

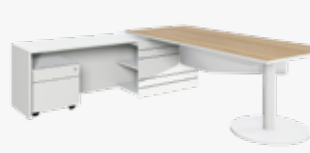

Geo Verse 2



Geo Executive Selectric

## Delta Executive Desks

- Unique, stylish and solid with modern profile
- Polished stainless steel legs make a statement in this desk range
- Legs also available in black
- Desk tops available in a wide range of colours
- Rubber foot pads
- Made in Australia to your specifications



White



Beech



Jarra

# Reception Desks

## First impressions count!

We know when you are searching for the perfect reception area, you need something to impress at an affordable price. All Storage Systems can offer you both of these benefits with our wide range of impressive reception counters. From our great quick ship range to a purpose built masterpiece, we can design, manufacture, deliver and install.



## Axis Reception Desk

- Proudly Australian designed and made to a high quality
- Many line style options available
- Choice of 42 colour options

Code	Dimensions (mm)
336053	(2100W x 900D) x (1800W x 600D) x 1072H
336054	(2400W x 900D) x (1800W x 600D) x 1072H



## Trilux Reception Desk

- Optional LED light under feature panel
- Comes with adjustable feet and 3 cable holes
- Excellent economical option without compromising on style

Code	Dimensions (mm)
336055	2216W x 820D x 1153H



## Deluxe Reception Desk

- Available in beech, redwood/grey or wenge/silver
- Supplied flat-packed for quick and easy assembly
- 25mm high quality construction
- Also available in other sizes

Code	Dimensions (mm)
330101	1800W x 750D
330100	3000W x 750D



## Modulus Boardroom Tables



- Simple timeless design with one universal leg style that works with many table sizes
- Frames are matte black powder coat with polished alloy feet
- Levelling guides on all feet
- High quality - 10 year guarantee
- Huge range of sizes available - talk to the team about your needs



## Typhoon Boardroom Table

- Modern style boardroom table
- Available with a range of table top colours
- Adjustable chrome feet and black powder coated rails
- 3 year warranty

Code	Dimensions (mm)
338106	1800L x 900W
338107	2400L x 1200W
338108	3200L x 1200W



## Deluxe Boat Boardroom Table

- Quick ship option - supplied flat-packed for easy assembly
- Available in 3 colour combinations

Code	Description	Dimensions (mm)
330231	Table Top	2400W x 1200D x 720H
330232	Table Base	



## Scope Boardroom Table

- Available with 4 different shape top options
- Wide range of table top colours available
- Made to your specifications in Australia

Code	Dimensions (mm)
338110	2400 x 1200 x 725H
338111	3000 x 1500 x 725H
338112	3600 x 1500 x 725H



## Vista Boardroom Table

- Available with 4 different shape top options
- Wide range of table top colours available
- Made to your specifications in Australia
- Choose either black or white powder coated base

Code	Dimensions (mm)
338113	2100 x 900 x 725H
338114	3000 x 1200 x 725H
338115	3600 x 1500 x 725H



## Rectangular Boardroom Table

- Available with cherry, beech, or white top
- 3 year warranty

Code	Dimensions (mm)
331282	3200 x 1200 x 730H



## Verse Coffee Table

- Available with either square or round tops in a wide range of colours
- High quality and clean looking versatile tables

Code	Description	Dimensions (mm)
338501	Round Top	600D x 450H
338502	Square Top	600D x 600W x 450H



## Glass Coffee Table

- Black glass with chrome frame
- 3 year warranty

Code	Dimensions (mm)
336001	600 x 600
336002	1200 x 600



## Steel Frame Table

- Solid economical option with 25mm top
- Choose either warm white, beech, cherry or natural oak top
- Adjustable levelling feet

Code	Dimensions (mm)
331200	1200 x 600
331201	1500 x 750
331202	1800 x 750
331203	1800 x 900



## Meeting Table

- Silver steel angled legs
- Choose either warm white, beech, cherry or natural oak top
- Great multi-use table

Code	Dimensions (mm)
332150	1800 x 900
332151	1800 x 750





## Fold & Roll Table

- Black frame with polished alloy feet
- Wide range of top colours available
- Quality tables with a 5 year warranty

Code	Dimensions (mm)
330220	1500L x 750D x 735H
330221	1800L x 750D x 735H



## Steel Frame Folding Table

- Powder coated black folding frame base
- Choose either warm white, beech, cherry or natural oak top
- 3 year warranty

Code	Dimensions (mm)
331210	1500 x 750
331211	1800 x 750
331212	1800 x 900



## Scope Tables

- Scope tables come in a wide range of size and style options
- Ideal for breakout areas, lunchrooms, libraries or meeting rooms
- Made to your specifications in Australia
- Talk to our team about your needs!



## Task Chairs

### Ellerslie

- Adjustable seat tilt and fixed arms
- Mesh back
- 120kg capacity



Code

350060

### Intro

- Adjustable weight tension
- Mesh back
- 120kg capacity



Code

350020

### ET20

- Medium back
- Seat and back tilt
- 3 year warranty



Code

350001

### Eco

- Medium back
- Seat and back lift
- AFRDI level 6



Code

350000

### P350

- Three lever mechanism
- Moulded seat and back foam
- AFRDI level 6



Code

350083

### Eldene

- Three lever mechanism
- Ratchet adjustable back
- 120kg capacity



Code

350056

### Forrest

- Seat and back tilt
- Moulded foam
- 120kg capacity

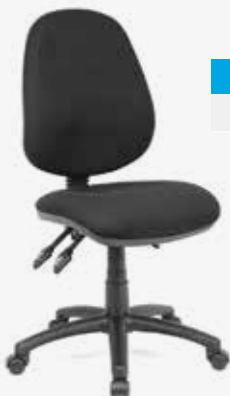

Code

350058

### Rio

- Three lever mechanism
- Adjustable mesh back
- AFRDI level 6

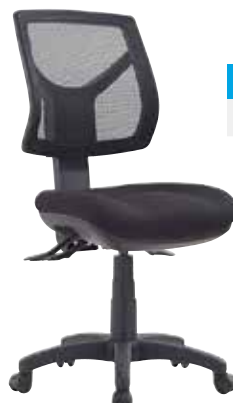

Code

350054

### Canterbury

- Adjustable back and seat tilt
- Mesh back
- 6 year warranty

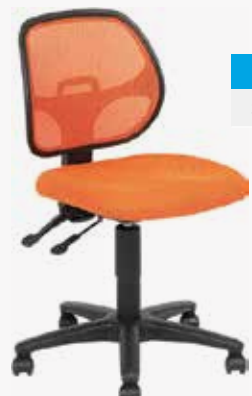

Code

350053

## Task Chairs

### Toorak

- Australian made
- Anti-bacterial
- Fire retardant



Code

350088

### Bentleigh

- Australian made
- Anti-bacterial
- Fire retardant



Code

350089

### Hawthorn

- Australian made
- Anti-bacterial
- Fire retardant



Code

350090

### Balcombe

- Three lever mechanism
- Large moulded seat
- AFRDI level 6



Code

350008

### Track

- Three lever mechanism
- Large seat
- AFRDI level 6



Code

350002

### Hino

- Three lever mechanism
- Adjustable mesh back
- AFRDI level 6



Code

350004

### Gifford

- Synchron mechanism with 3 locking positions
- Auto weight tensioning
- Adjustable lumbar support



Code

350097

### Robertson

- 3 lever heavy duty mechanism
- Moulded seat foam
- AFRDI level 6 rating



Code

350099

### Bomba

- Three lever mechanism
- Adjustable mesh back
- Available with and without arms



Code

350018

## Task Chairs

### Urban

- 3 lever mechanism
- Adjustable height and angle
- Mesh back



Code  
350081

### Optic

- Mesh backrest for added breathability
- Adjustable lumbar support
- BIFMA tested and certified



Code  
350084

### Roma

- Three lever mechanism
- Adjustable back height
- 10 year warranty
- High and low back available



Code  
350085

### Swift

- Three lever mechanism
- Adjustable mesh back
- Seat slider



Code  
350045

### Spark

- Three lever mechanism
- Adjustable back and lumbar pump
- Seat slider



Code  
350043

### Florence

- Three lever mechanism
- Moulded foam seat
- Nylon base and castors



Code  
350094

### Berwick

- Three lever mechanism
- Available in medium and high back
- 3 year warranty



Code  
350014

### Delta

- Adjustable seat and back tilt
- Ratchet adjustable back
- 10 year warranty



Code  
350047

### Rexa Manual

- Twin lever mechanism
- Adjustable back height
- 10 year warranty



Code  
350049

## Executive Chairs Cleeve

- Entry level executive chair
- Free float or locking mechanism
- Available in black PU only



Code  
351012

## Camry

- Adjustable seat and back angle
- Heavy duty aluminium arms
- Available in black PU only



Code  
351006

## Diablo Manager

- Adjustable seat and back angle
- Black mesh back
- Seat slider



Code  
351021

## Enterprise

- Three lever mechanism
- Complete with arms
- 180kg capacity



Code  
351000

## Diablo Executive

- Adjustable seat and back angle
- Mesh back
- Removable headrest



Code  
351009

## Canberra

- Infinite tilt lockable mechanism
- Tension adjustment
- Padded fixed arms



Code  
351015

## Bailey

- Perforated mesh seat
- Height adjustable arms
- 180kg capacity



Code  
351022

## Vader

- High back
- Padded arms
- 5 star chrome base



Code  
351002

## Boston

- Adjustable seat and back angle
- High density foam
- Available in black PU only



Code  
351005

## Executive Chairs

### Logan

- Three lever mechanism
- Fully upholstered
- Available with or without arms



Code
351004

### Hume

- Adjustable seat and back angle
- Adjustable arms
- Available in black PU only



Code
351027

### VX3 Task Chair

- Three lever synchro mechanism
- High density contoured moulded foam seat
- Flexing lumbar support



Description	Code
With Arms	350092
Without Arms	350091

### Balance

- Synchro mechanism
- Mesh back
- 10 year warranty



Code
351008

### Spark Posture Soft

- Three lever mechanism
- Posture soft memory foam
- Ratchet height adjustable backrest



Code
350080

### Regal

- Adjustable seat and back angle
- Synchro mechanism
- Available in a range of fabrics



Code
351029

### Parker

- Heavy duty synchro mechanism
- High density moulded foam
- Mesh back with lumbar support



Code
351030

### Vivid

- Weight balance synchro mechanism with 4 position tilt lock
- 3D height adjustable arm rests
- High density moulded foam seat



Code
351034

### Horizon

- Weight balance synchro mechanism with 3 position tilt lock
- Full flexing ribbed lumbar & spine system
- High density moulded foam seat



Code
350093

## Visitors Chairs

### Tempo

- Linking and stackable frame
- Fabric seat and powder coated sled base



Code

352046

### Piper Heavy Duty Stacking Chair

- Durable stacking chair for heavy duty use
- Black powder coated steel frame
- 130kg weight capacity



Code

352023

### Nova Chair

- Linking and stackable frames
- Available in black, navy or charcoal



Code

352000

### Prorod Chair

- Stackable chrome frame
- Available in a range of upholstery fabrics



Code

352007

### Star Chair

- Fully upholstered in a wide range of fabrics
- Arms available as optional extra
- Strong black stackable frame



Code

352005

### Maddison Chair

- Stackable strong frame with 3 year warranty
- Available in a wide range of upholstery fabrics



Code

352011

### Wilmer Mesh Back Chair

- Comfortable mesh back chair for breakout or library areas
- 120kg weight capacity
- 5 year warranty
- Stackable



Code

352016

### Evo Chair

- Economical stackable chair
- Available in a range of fabrics



Code

352020

### Rosella

- Perfect for schools or library areas
- Range of colours available



Code

352028



## Acti Chairs

The Acti Chair is a truly versatile range of seating for any visitor, guest or waiting area; libraries, training or seminar rooms; meeting or breakout areas; or anywhere a bright, comfortable and practical chair is required.

- Flexible back allowing movement whilst seated
- Available in 12 shell colours
- 5 year warranty
- Stackable option for where storage is limited
- 110kg weight rating
- Wide range of bases - chrome 4 leg, sled, timber, swivel or bar stool
- Padded seat or fully upholstered optional



[View the full flyer](#)





**Acti 4 Leg**  
352004A



**Acti Sled Base**  
352006A



**Acti Timber Base**  
352012A



**Acti Bar Stool (High)**  
352009A



**Acti Swivel Base**  
350007A

Dimensions	Side Chairs			Swivel Chairs	Bar Stools			
	4 Leg Chair (Metal)	4 Leg Chair (Timber)	Sled Chair (No Arms)	Swivel Chair (No Arms)	4 Leg Bar Stool (Low)	4 Leg Bar Stool (High)	4 Leg Bar Stool (Low No Arms)	4 Leg Bar Stool (High No Arms)
<b>Seat Height</b>	445mm	445mm	445mm	325mm-555mm	630mm	760mm	630mm	760mm
<b>Seat Width</b>	470mm	470mm	470mm	470mm	470mm	470mm	470mm	470mm
<b>Back Height</b>	370mm	370mm	370mm	370mm	370mm	370mm	370mm	370mm
<b>Overall Width</b>	540mm	480mm	560mm	600mm	525mm	530mm	550mm	550mm
<b>Overall Height</b>	790mm	790mm	790mm	670mm-900mm	1000mm	1130mm	980mm	1100mm
<b>Overall Depth</b>	505mm	495mm	495mm	600mm	500mm	530mm	515mm	510mm
<b>Seat Depth</b>	370mm	370mm	370mm	370mm	370mm	370mm	370mm	370mm
<b>Weight Rating</b>	150kg	130kg	150kg	110kg	110kg	110kg	110kg	110kg

### Shell Colours



### Frame Colours

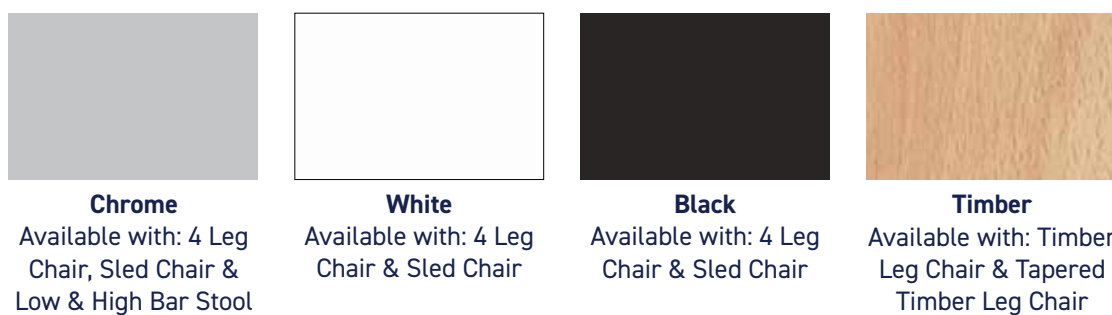

## Plaza Reception Lounges

- Available as 1, 2 or 3 seater lounges
- Solid hardwood frame, webbed base and pocket spring seat
- 5 year warranty
- Loose reversible cushions

Code	Description
353013	1 seater
353014	2 seater
353015	3 seater



## Eadie Chair

- Available in mustard, teal or charcoal upholstery
- High density resilience foam
- Fully assembled with 2 year warranty



Code  
352034

## Aries Stool

- Stylish metal leg stool
- Choose either black, grey or green seat
- 3 year warranty



Code  
352035

## Zoom Conference Chair

- Mesh back conference chair
- Foldable with nesting capabilities
- 5 year warranty
- Upholstered seat adds extra comfort



Code  
352018

## Raven Padded Chair

- Modern upholstered sled base chair
- Available in red or black fabric
- 5 year warranty



Code  
352033

## Konnect Modular Range

- The highly configurable Konnect range suits a wide range of areas
- Available in grey or dark grey upholstery
- Very popular range that is comfortable and affordable
- Konnect coffee table includes charging station and USB ports
- Seat height – 420mm



Code	Description	Dimensions (mm)
353010	Corner	750W x 750D x 710H
353011	Middle	550W x 750D x 710H
354003	Ottoman	550W x 750D x 420H
353012	Konnect Box	300W x 250D x 380H



## Dime Ottomans

- Made in Australia
- Available in a wide range of fabrics and colours
- 5 year warranty
- Heavy duty commercial foam and manufactured to a strict commercial standard

Code	Dimensions (mm)
354000	450D
354001	900D



## Clip Ottomans

- Solid hardwood frame with chrome legs
- 130kg load rating
- Available in a wide range of fabric choices
- Very configurable - works well in any size breakout area

Code	Dimensions (mm)
354004	620D x 380/720W x 390H



## Monitor Arms

- Flexible and strong monitor arms giving you a more comfortable ergonomic work area
- Comes with 2 x USB charging ports and 1 x audio headphone port
- Clamp to desk or cable port
- Fits 10" - 27" size monitors



Code	Description
322202	Single Monitor Arm
322203	Dual Monitor Arm

## Chair Mats

- Dimpled for use on carpet and smooth for use on hard floors



Code	Description	Dimensions (mm)
322100	Dimpled	1350 x 1150
322101	Dimpled	1200 x 915
322102	Smooth	1350 x 1150
322103	Smooth	1200 x 915

## Topo Anti Fatigue Mat

- Ideal partner for a standing desk
- Calculated terrain facilitates blood flow and encourages movement
- Highly durable comfortable foam



Code	Dimensions (mm)
322104	736W x 637L



## Steppie Board

- Balance boards are designed for people with sit/stand desks
- Minimal movement allows you to stand for longer without aching
- Encourages better posture and reduces muscular tension
- Supports up to 200kg



Code	Dimensions (mm)
322002	360 x 560mm

## Footrests

- Fluteline - Made in New Zealand and boasting a 5 year warranty. Both height and slope adjustable - tailor it to your personal need
- Z-Rest - Easy operation - adjust without leaving your seat! Sleek and sturdy aluminium construction
- Fellowes Adjustable - Economical option - either lock into position or rock back and forth stimulating blood flow

Code	Description
322003	Fluteline Footrest
322001	Z-Rest Footrest
322000	Fellowes Adjustable Footrest

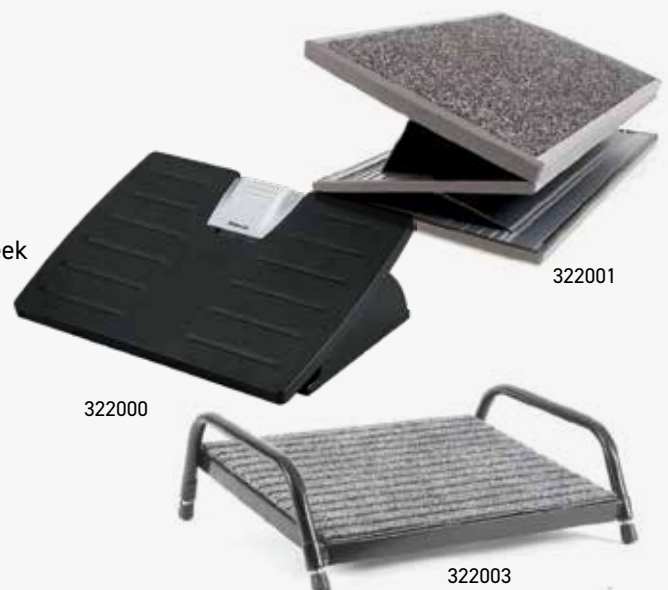

## Counter Standing Holders

	Code	Description	Dimensions (mm)
A	410000	Vertical Business Card Holder	56W x 18D
B	410001	Landscape Business Card Holder	93W x 18D
C	410004	DL Landscape Holder	230W
D	410005	DL Portrait Holder	104W
E	410015	A5 Portrait Holder	160W
F	410030	A4 Portrait Holder	230W
G	410006	Double DL A4 Holder	112 x 30 (x2)
H	410032	A4 x 4 Compartment Holder	230W (x4)
I	410031	A4 x 3 Compartment Holder	230W (x3)
J	410016	A5 x 4 Compartment Holder	160W (x4)
K	410007	DL x 4 Compartment Holder	104W (x4)

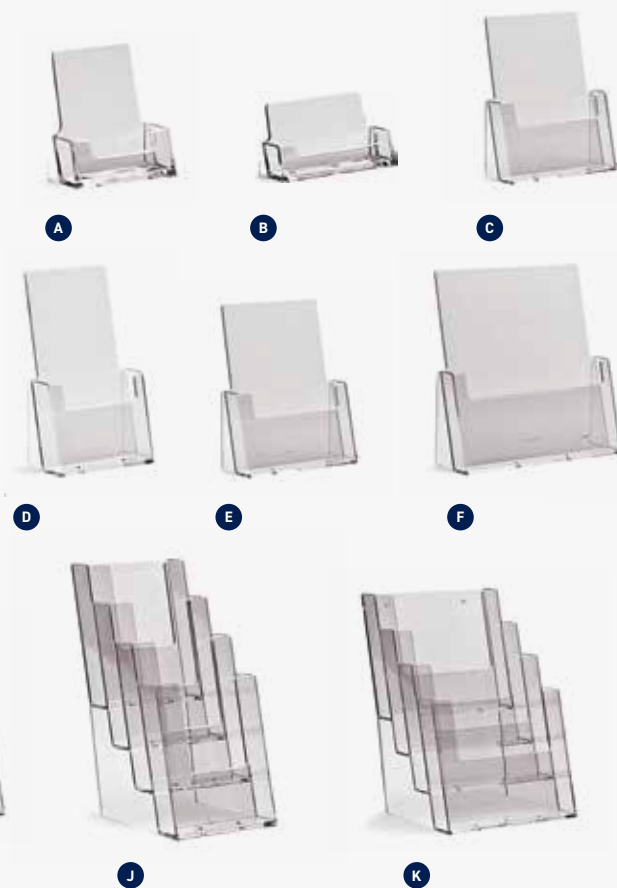

## Wall Mountable Holders

	Code	Description	Dimensions (mm)
A	411020	Business Card Holder	93 x 18
B	411022	DL Landscape Brochure Holder	230 x 30
C	411021	DL Portrait Brochure Holder	104W
D	411023	DL x 4 Brochure Holder	104W (x4)
E	411026	A4 Portrait Brochure Holder	230W
F	411025	A5 Portrait Brochure Holder	160W
G	411027	A4 x 3 Brochure Holder	230W (x3)



## Steel Brochure Holders

- Robust steel construction
- Durable powder coat finish



	Code	Description	Dimensions (mm)
A	411550	DL Brochure Holder	104 x 155 x 30
B	411551	A4 Brochure Holder	230 x 240 x 30
C	411552	A3 Landscape Brochure Holder	430 x 240 x 30
D	411553	11 Pocket Magazine Holder	254 x 915 x 105
E	411554	20 Pocket Magazine Holder	254 x 1500 x 105

## Wall Pockets



Code	Description	Colour	Dimensions (mm)
411000	Portrait	Clear	260W x 254H x 102D
411001	Landscape	Clear	375W x 178H x 102D
411002	Portrait	Smoke	260W x 254H x 102D
411003	Landscape	Smoke	375W x 178H x 102D

## Weatherproof Display Box



Code	Dimensions (mm)
411010	333W x 254H x 114D

## Brochure Stands & Baskets



	Code	Description
A	412000	10 Pocket A4 Stand
	412001	20 Pocket A4 Stand
B	412005	Acrylic Catalogue Basket
C	412003	Small Wire Catalogue Basket- 750mmH
D	412004	Catalogue Basket with Sign Holder - 940mmH

# Sign Holders

## Slanted Sign Holder

Code	Description
430000	A7 Portrait
430001	A6 Portrait
430002	A5 Portrait
430003	A4 Portrait
430004	A3 Portrait
430005	Trifold Portrait
430006	A5 Landscape
430007	A4 Landscape
430008	A3 Landscape



## Double Sided Sign Holder

Code	Description
430015	A7 Portrait
430016	A6 Portrait
430017	A5 Portrait
430018	A4 Portrait
430019	A3 Portrait
430020	Trifold Portrait
430021	A5 Landscape
430022	A4 Landscape
430023	A3 Landscape



## Manhattan Classic Snap Frames

- Can be used portrait or landscape
- 25mm mitred corner frame
- Plastic backing board
- Available in silver and black

Code	Description
431050	A5
431051	A4
431052	A3
431053	A2
431054	A1



# Rite Snap Frames

- Heavy duty round cornered design
- Aluminium composite backing with clear perspex sheet to protect your poster

## Single Snap Frames

Code	Description
431000	A4
431001	A3
431002	A2
431003	A1
431004	A0



## Snap A Frame

Code	Description
431005	500 x 700
431006	594 x 841 (A1)
430007	700 x 1000



## Poster Display Case

Code	Description
431010	A2
431011	A1



## Pedestal Snap Frame

Code	Description
431008	A4 Portrait
431009	A3 Landscape

# Expanda Stand Interchangeable Brochure Display System

- Flexible, integrated and innovative brochure display system
- Ability to change display configurations to suit your needs
- Easy install modular display system

Code	Description
411225	A4
411226	A5
411227	DL (1/3 A4)
411228	Postcard Portrait
411229	Postcard Landscape
411205	Base Bracket

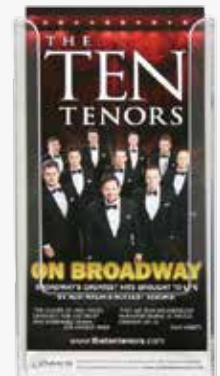

## Wall Brochure Holders

- Easy install modular wall systems

Code	Description	Dimensions (mm)
411211	8 x A4	450 x 750
411213	8 x DL & 4 x A4	450 x 520
411215	16 x DL	450 x 430
411212	16 x A4	900 x 750
411214	16 x DL & 8 x A4	900 x 680
411216	32 x DL	900 x 430

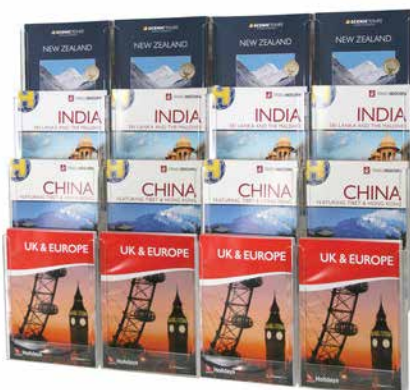



## Expanda Stand Brochure Display Carousels

- Freestanding brochure display systems
- Available in gold, silver or black
- Fast and easy to assemble
- Displays brochures on all three sides
- Display pockets interchangeable with wall mount displays and lobby stands
- 1760mm high overall

	Code	Description
A	412024	18 A4 Brochure Holders
B	412025	18 A5 Brochure Holders
C	412026	18 A4 & 36 DL Brochure Holders
D	412027	48 x DL Brochure Holders



## Expanda Stand Lobby Stands

- Freestanding modern brochure stand
- Single sided brochure display
- Available either 1460 or 1800mm high

	Code	Description	Dimensions (mm)
A	412100	8 A4 Holders ( 2 Across 4 Down)	1460 x 500 x 300
B	412101	16 DL Holders ( 4 Across 4 Down)	1460 x 500 x 300
C	412102	16 A4 Holders ( 2 Across 8 Down)	1800 x 500 x 300
D	412103	32 DL Holders ( 4 Across 8 Down)	1800 x 500 x 300



# Slatwall

## Slatwall Panels

- Versatile merchandising system
- Available in a wide range of colours

Code	Dimensions	Colour
423000	2400L x 1200H	White
423004	2400L x 1200H	Grey, Beech or Black

## Aluminium Extrusions

Code	Dimensions (mm)
423100	2400L



### Slatwall Spinner Unit

- Slots are spaced at 100mm intervals
- Compatible with all slatwall fittings
- Flat-packed for easy assembly
- Available in black, white or beech

Code	Dimensions (mm)
423202	1380L x 4 Sides 350W



### Slatwall Cross Spinner Unit

- Slots are spaced at 100mm intervals
- Compatible with all slatwall fittings
- Flat-packed for easy assembly

Code	Dimensions (mm)
423203	900Ø x 1430H



## Slatwall Brackets

- Versatile and easy to use
- Available in chrome, black or white

Code	Dimensions (mm)
420200	150
420201	200
420202	250
420203	300
420204	350
420205	400
420209	450
420206	300 - Adjustable
420207	Shelf Clip w Rubber Bumper



## Melamine Shelves

- Available in a wide range of colours

Code	Dimensions (mm)
420230	600 x 200
420231	900 x 300
420232	1200 x 300
420233	1500 x 300
420234	1800 x 300
420235	2400 x 300



## Glass Shelves

- 8mm tempered safety glass

Code	Dimensions (mm)
420236	595 x 200
420237	595 x 300
420238	595 x 400
420239	895 x 200
420240	895 x 300
420241	895 x 400
420242	1195 x 200
420243	1195 x 300
420244	1195 x 400

# Slatwall Accessories

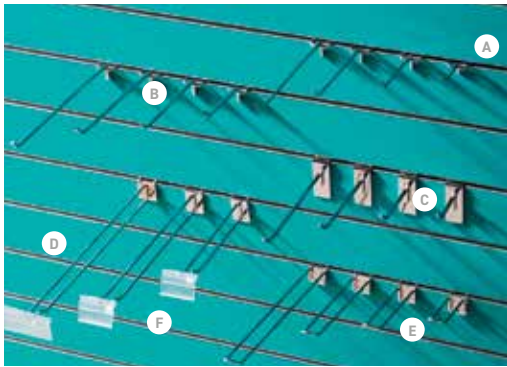

## Slatwall Hooks

	Code	Description	Dimensions (mm)
A	420000	Standard Duty 3.8mm Wire	50
A	420001	Standard Duty 3.8mm Wire	100
A	420002	Standard Duty 3.8mm Wire	150
A	420003	Standard Duty 3.8mm Wire	200
B	420004	Heavy Duty 6mm Wire	100
B	420005	Heavy Duty 6mm Wire	150
B	420006	Heavy Duty 6mm Wire	200
B	420007	Heavy Duty 6mm Wire	250
B	420008	Heavy Duty 6mm Wire	300
C	420009	Metal Prong	75
C	420010	Metal Prong	100
C	420011	Metal Prong	150
C	420012	Metal Prong	200
C	420013	Metal Prong	250
C	420014	Metal Prong	300
D	420015	Scanning Hook	100
D	420016	Scanning Hook	150
D	420017	Scanning Hook	200
D	420018	Scanning Hook	250
D	420019	Scanning Hook	300
E	420020	Double Prong Hook	100
E	420021	Double Prong Hook	150
E	420022	Double Prong Hook	200
E	420023	Double Prong Hook	250
E	420024	Double Prong Hook	300
F	420053	Label Holder	50 x 26
F	420054	Label Holder	80 x 26

## Straight Arm



Code	Dimensions (mm)
420043	300
420044	400

## Sloping Faceout



Code
420045

## Handbag Faceout



Code
420047

## Hat/Ball Display



Code
420046

## Wire Baskets

Code	Dimensions (mm)
420040	300 x 150 x 150
420041	300 x 300 x 200
420042	600 x 300 x 100

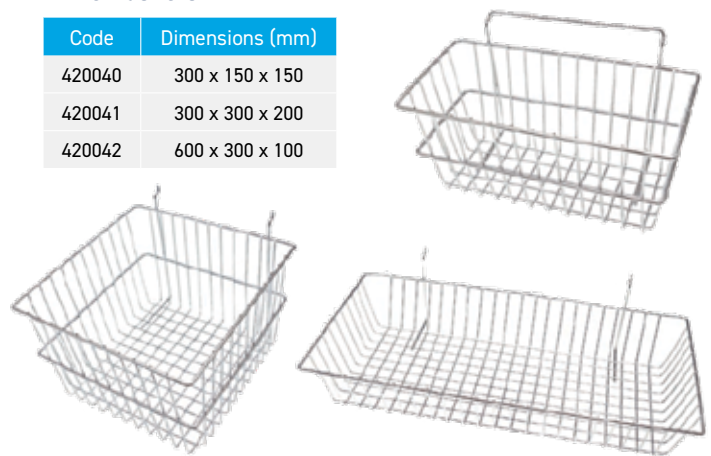

## Acrylic Shelf



Code	Dimensions (mm)
420056	250 x 100

## Acrylic Display Bin



Code	Dimensions (mm)
420057	293 x 200 x 150H

## Acrylic Display Bin Low Front



Code	Dimensions (mm)
420058	293 x 200 x 40H

## Acrylic Display Bin 2 Compartments



Code	Dimensions (mm)
420059	293 x 155 x 100H



## ALSTOR™ Gondola Shelving

- Cost effective display solution
- Available in single or double sided
- White or black finish
- Range of accessories available
- Available in three heights

### Single Sided

Code	Description	Dimensions (mm)
423588	Starter Bay	1520H x 935W x 525D
423584	Starter Bay	1800H x 935W x 525D
423580	Starter Bay	2120H x 935W x 525D
423589	Extension Bay	1520H x 935W x 525D
423585	Extension Bay	1800H x 935W x 525D
423581	Extension Bay	2120H x 935W x 525D

### Double Sided

Code	Description	Dimensions (mm)
423582	Starter Bay	1520H x 935W x 980D
423586	Starter Bay	1800H x 935W x 980D
423590	Starter Bay	2100H x 935W x 980D
423583	Extension Bay	1520H x 935W x 980D
423587	Extension Bay	1800H x 935W x 980D
423591	Extension Bay	2100H x 935W x 980D



# Slotmesh

## Panels

Code	Dimensions (mm)	Colour
421000C	600W x 1200H	Chrome
421000B	600W x 1200H	Black
421001C	600W x 1500H	Chrome
421001B	600W x 1500H	Black
421002C	600W x 1800H	Chrome

## Accessories

Code	Dimensions (mm)	Colour
421021C	Wallmount Hook	Chrome
421021B	Wallmount Hook	Black
421022C	Panel Connector	Chrome
421022B	Panel Connector	Black
421020C	Panel Legs - Pair	Chrome
421020B	Panel Legs - Pair	Black

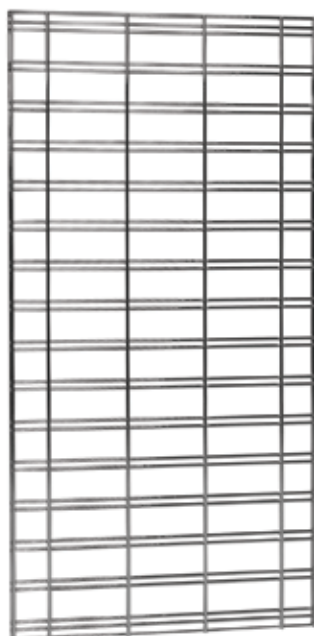

## Slotmesh Triangle Base



Code	Dimensions (mm)
421023	680 x 680 x 680

## Slotmesh Triangle

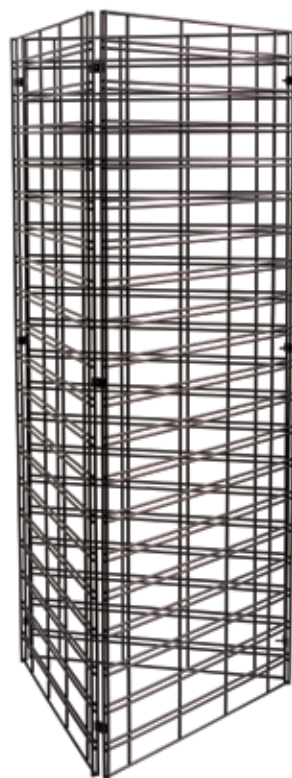

Code	Dimensions (mm)
421003	1500 x 600 x 600

# Wall Stripping

**Stripping** Colours Available: Chrome or White

Code	Description	Dimensions (mm)
422000	Single Slot	1500
422001	Single Slot	1780
422002	Single Slot	2100
422003	Single Slot	2380
422010	Double Slot	1500
422011	Double Slot	1780
422012	Double Slot	2100
422013	Double Slot	2380



## Brackets

Code	Dimensions (mm)
422020	250
422021	300
422022	350
422023	400
422024	450



## Hangrail

Code	Dimensions (mm)
422033	1200
422034	1800

Available in Chrome only



## Hangrail Bracket

Code	Dimensions (mm)
422031	345

Available in Chrome only

## Collapsible Dump Bin



Code	Dimensions (mm)
440100	450sq x 760H
440101	590sq x 760H

Colours Available: Black or White

## Collapsible Display Table



Code	Dimensions (mm)
440102	900 x 600 x 800H
440103	1200 x 600 x 800H

## Round Rack



Code	Dimensions (mm)
440003	840Ø x 1080-1520H

## Spiral Rack

- 28 Hanging positions



Code	Dimensions (mm)
440002	1750H

## 4-Way Rack



Code
440005

## Collapsible Rails



Code	Description	Dimensions (mm)
440000	Single Rail	1280L x 1450-1700H
440001	Double Rail	1280L x 1450-1700H

## Adhesive Ticket Stripping



Code	Dimensions (mm)
440140	914 x 26
440141	1200 x 26

Other sizes available

## Shopping Baskets



Code	Dimensions (mm)
440200	430 x 330 x 230H

Colours: Red, Green, Black, Blue, Yellow

## Shopping Basket Stand



Code	Dimensions (mm)
440201	380 x 240 x 400H

## Budget Square Tower Showcase

- Four shelves
- On wheels with lockable door
- Flat-packed for easy assembly
- Available with black or white aluminium frame

Code	Dimensions (mm)
441005	400 x 400 x 1580H



## Budget Four Shelf Showcase

- On wheels with lockable door
- Flat-packed for easy assembly
- Available with black or white aluminium frame

Code	Dimensions (mm)
441006	770 x 400 x 1580H



## Aluminium Tower Showcase

- Four shelves
- LED lights
- Lockable door
- Flat-packed for easy assembly
- Available with black or white aluminium frame

Code	Dimensions (mm)
441007	500 x 500 x 1980H



## Aluminium Tall Showcase

- Four shelves
- LED lights
- Lockable door
- Flat-packed for easy assembly
- Available with black or white aluminium frame

Code	Dimensions (mm)
441008	1200 x 500 x 1980H



## Product Index

A	
Access Platforms	61
Accessories to suit Trade Series Ladders	60
Acti Chairs	104-105
Activity and Combination Racks	26-27
Adhesive Ticket Stripping	118
Aerosol Cases	43
All-Terrain Scissor Lift	48
Angle Post Shelving	23
Anti Fatigue Mat	108
Anvil Desking	78-79
Aries Stool	106
Axis Desking	76-77
B	
Boardroom Tables	94-95
Bollards	64
Bolt on Cage	47
Box and Bag Trolley	57
Brochure Stands & Baskets	110
Bunded Pallets	45
Bunded Shelving	45
C	
Cable Racking	19
Cantilever Racking	18
Chair Mats	108
Clax Cart	56
Cleanspan Chrome Wire Shelving	24
Cleanspan Overhead Rail Units	25
Cleanspan Trolleys	25
Clothing Racks	118
Coffee Tables	96
Collapsible Display Table	118
Collapsible Dump Bin	118
Collapsible Mesh Stillage Cage	46
Collapsible Rails	118
Container Ramp	51
Convex Mirrors	62
Corkboard	74
Corrosive Substance Storage Cabinets	44
Counter Standing Holders	109
D	
Deluxe Infinity Office Furniture	91
Deluxe Office Furniture	86-87
Desk Risers	82-83
Document Storage	37
Drawer Units	38
E	
Eadie Chair	106
Economy Van Rack	40
Elite Office Furniture	84-85
Enviroskate & Handle	34
Executive Chairs	101-102
Executive Desks	92
Expanda Stand Brochure Display Carousels	113
Expanda Stand Interchangeable Brochure Display System	112
Expanda Stand Lobby Stands	113
F	
Filing Cabinets	68
Flammable Liquid Storage	42
Fold & Roll Table	97
Footrests	108
Forklift Extension Slippers	51
Forklift LPG Stores	43
Forklift Safety Cages	49-50
Forklift Safety Harness	50
Free Track Mobile Storage Systems	69
G	
Gas Cylinder Storage	43
Glass Fronted Notice Boards	74
Gondola Shelving	116
H	
Hand Pallet Truck	48
Hanger Rack System	29
Heavy Duty Platform Trolleys	55
Heavy Duty Trolleys	55
Heavy Duty Utility Carts	54
Height Adjustable Desks	82-83
Hi-Vis T-Top Bollards	36
High Lift Pallet Truck	48
Hobby Box	35



## Product Index, continued

<b>I</b>		<b>P</b>	
Industrial Drawer Unit	38	Pallet Racking & Accessories	14-16
Industrial Storage Cabinet	38	Partitions	81
<b>J</b>		Parts Storage Cabinets	39
Johnson-Built Kwiklock Shelving	22	Parts Trays	32
Jumbo Teamstep	59	Pigeon Holes	71
<b>K</b>		Pinboards	75
Konnect Modular Range	107	Plastic Safety Chains	63
<b>L</b>		Platform Step Ladders	60-61
Large Appliance Trolleys	57	Plaza Reception Lounges	106
Lockers	70-71	Port-a-Guard Expanding Barriers	63
Longspan Shelving	8-11	Post Real Tuff Shelving	23
Louvre Panel	31	Post Wire Grid Shelving	23
Louvre Panel Kits	31	PPE Storage Cabinets	44
Lumiere Magnetic Glassboards	74	<b>R</b>	
Lunar Metal Mobile Caddy	72	Rapid Screens System & Accessories	80
Lunar Metal Mobile Pedestals	72	Rapid Span Office Furniture	90
<b>M</b>		Rapid Worker Office Furniture	88-89
Manual Hydraulic Scissor Lift	48	Raven Padded Chair	106
Meeting Table	96	Reception Desks	93
Mesh Galvanised Collapsible Cage	46	Rite Snap Frames	111
Mezzanine Floors	17	RK Shelf Containers	32
Mezzanine Roll-Over-Gate	63	Rolacase Systems	41
Mighty Parts Trolley	30	Rolashelf System	40
Mobile Kick Stool	59	Rolled Edge Shelving	28
Mobile Melamine Tote Box Trolleys	72	Round Brute	36
Mobile Metal Frame Tote Trolleys	72	Round Rack	118
Mobile Storage Units	69	<b>S</b>	
Mobile Tooling Cabinet	38	Safety Mirrors	62
Monitor Arms	108	Safety Signs	37
Monstar Step	59	Scooter Stool	59
Multi Purpose Hand Trucks	57	Scope Tables	97
<b>N</b>		Securespan Shelving	22
Nally Buckets	36	Security Crates	35
Nest Crates	35	Series 400 & 600 Bins	33
<b>O</b>		Shopping Basket Stand	118
Office File Trolley	56	Shopping Baskets	118
Order Picker Ladders	61	Side Access Crates	35
Ottomans	107	Sign Holders	111
		Slatwall & Accessories	114-115
		Sloping Top Cabinets	68

## Product Index, continued

<b>S</b>		<b>W</b>	
Slotmesh & Accessories	117	Wall Brochure Holders	112
Speed Humps	64	Wall Mountable Holders	109
Spill Kits	58	Wall Pockets	110
Spiral Rack	118	Wall Stripping	117
Square Hole Hanger Board & Accessories	29	Weatherproof Display Box	110
Stack & Nest Crates	34	Wheelie Bins	58
Stackable Stillages	46	Whiteboards	73
Stacking Totes	36	Wire Baskets	30
Steel Brochure Holders	110	Workbenches	12-13
Steel Cage	47	<b>X</b>	
Steel Frame Folding Table	97	X-Cart	56
Steel Frame Table	96	<b>Z</b>	
Steel Trolleys	53	Zoom Conference Chair	106
Steppie Board	108	<b>Numerical</b>	
Stock Roll Cage Trolley	54	4-Way Rack	118
Storage Cabinets	67		
Storage Cupboard with Mesh Doors	42		
Storpak Bins	32		
Studio 50 Screen System	80		
Supra Bins	33		
<b>T</b>			
Tambour Door Cabinets & Accessories	66		
Task Chairs	98-100		
Team Step-Up	59		
Teamstep	59		
Tiered Trolleys	52		
Tool Trolleys	52		
Tri-Bund Flexible Bunding	45		
TX Notice Cases	74		
Tyre Racking	20-21		
<b>U</b>			
Utility Cupboard	67		
<b>V</b>			
Vertical Cantilever Racking	19		
Visi-pak	33		
Visitors Chairs	103		





**Shepparton (Head Office)**

29 Drummond Road, Shepparton VIC 3630

**Melbourne (Appointment Only)**

115 McKellar Way, Epping VIC 3076



**Solutions for every workplace**

**CALL  
TODAY**

**1800 772 726**

All Storage Systems reserve the right to alter or amend product information and pricing as necessary without prior notice to customers.